

SPECIFICATIONS

Model No.

BRP3409L-30-TR

Page

1/5

1. ELECTRICAL AND ACOUSTICAL SPECIFICATION

	Item	Unit	Specifications
1-1	Rated Voltage (Square Wave)	Vp-p	10
1-2	Operating Voltage	Vp-p	1-30
1-3	* Rated Current (Max)	mA	9
1-4	* Min Sound Output at 1.1kHz/10cm	dB	85
1-5	* Resonant Frequency	Hz	1100±500
1-6	Capacitance at 120Hz	pF	50000±30%
1-7	Operating Temperature	°C	-20~+60
1-8	Storage Temperature	°C	-30~+70
1-9	Weight	g	5
1-10	Housing Material		Black ABS
1-11	Lead Wire		UL1095 AWG28
1-12	Tone Nature		Single

* Value Applying at Rated Voltage (resonant frequency, 1/2 duty, square wave)

		13.01.24	ZhuYu	Shi Cong	Wang Xue Wen
Issue No	Description	Date	Issue	Check	Approval

INTERNATIONAL COMPONENTS CORPORATION

SPECIFICATIONS

Model No.

BRP3409L-30-TR

Page

2/5

2.ENVIRONMENTAL TEST

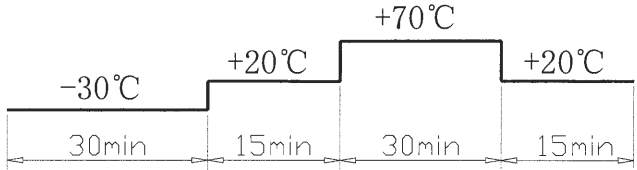
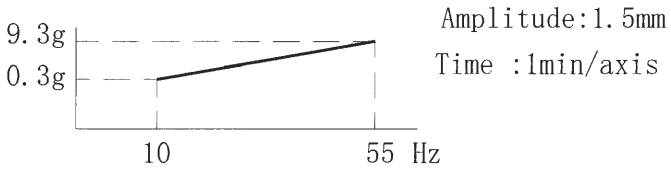
Item	Specifications
2-1 Storage in High temp.	Storage in $+70^{\circ}\text{C} \pm 2^{\circ}\text{C}$ test box for 240 hours, then expose to the room temperature for 2 hours without applying power.
2-2 Storage in Lower temp.	Storage in $-30^{\circ}\text{C} \pm 2^{\circ}\text{C}$ test box for 240 hours, then expose to the room temperature for 2 hours without applying power.
2-3 Storage in Humidity	Storage in $+40^{\circ}\text{C} \pm 2^{\circ}\text{C}$ 90-95%RH test box for 96 hours, then expose to the room temperature for 2 hours without applying power.
2-4 Thermal cycle test.	 <p>Make this test for 5 cycles without applying power, then expose to the room temperature for 2 hours.</p>
2-5 Vibration test	 <p>Make this test for the directions of X,Y, Z for 2 hours each (total 6 hours).</p>
2-6 Drop test	Free drop a unit from the height 100cm to the surface of 10mm thick board ,three directions(X,Y,Z).

PASS CRITERION :

After these tests , the change of S.P.L shall be within ± 5 dB .

		13.01.24	ZhuYu	ShiCong	WangXueWen
Issue No	Description	Date	Issue	Check	Approval

INTERNATIONAL COMPONENTS CORPORATION

SPECIFICATIONS

Model No.

BRP3409L-30-TR

Page

3/5

3.MEASURING METHOD(BUZZER MODE)

3-1 .Test Condition

3-1-1.STANDARD

Temperature : $25 \pm 3^{\circ}\text{C}$

Relative humidity : 60% ~ 70%,

Atmospheric pressure : 860mbar to 1060mbar

3-1-2.JUDGEMENT

Temperature : $15 \sim 35^{\circ}\text{C}$

Relative humidity : 45% ~ 85%,

Atmospheric pressure : 860mbar to 1060mbar.

3-2 . Standard Test Fixture

1.rated Voltage(Square wave):10V

2.Resonant Frequency:1100Hz

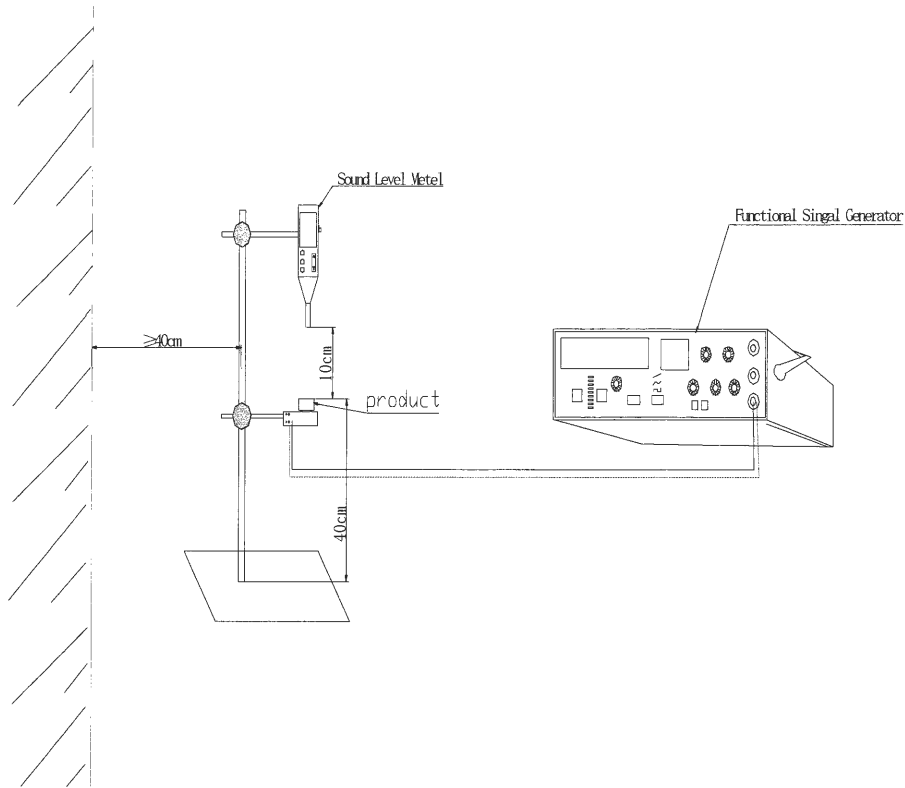

		13.01.24	ZhuYu	ShiCong	WangXueWen
Issue No	Description	Date	Issue	Check	Approval

INTERNATIONAL COMPONENTS CORPORATION

SPECIFICATIONS

Model No.

BRP3409L-30-TR

Page

4/5

5.DIMENSIONS

Unless otherwise specified, tolerance: ± 0.5 (unit:mm)

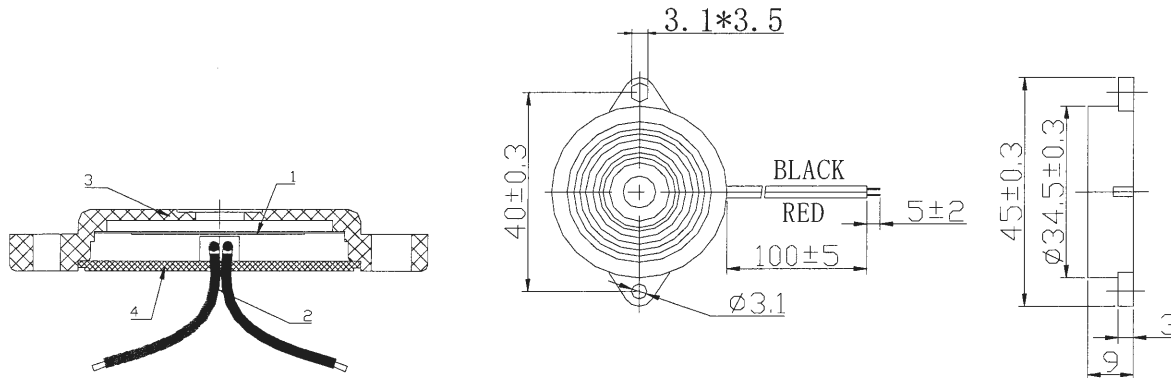

- 1) All parts must be meet to ROHS.
- 2) Wave solder and wash not allowed.

7				
6				
5				
4	Cover	1	Black ABS	
3	Housing	1	Black ABS	
2	Lead wire	2	Black&Red (UL1095 AWG28)	
1	Piezo element	1	Brass	
Part No.	Part Name	Q'TY	Material	Remark

		13.01.24	ZhuYu	ShiCong	WangXueWen
Issue No	Description	Date	Issue	Check	Approval

INTERNATIONAL COMPONENTS CORPORATION

SPECIFICATIONS

Model No.

BRP3409L-30-TR

Page

5/5

6.PACKING

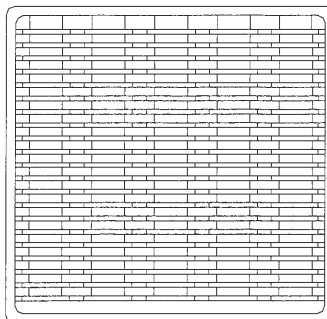

每盒放50只

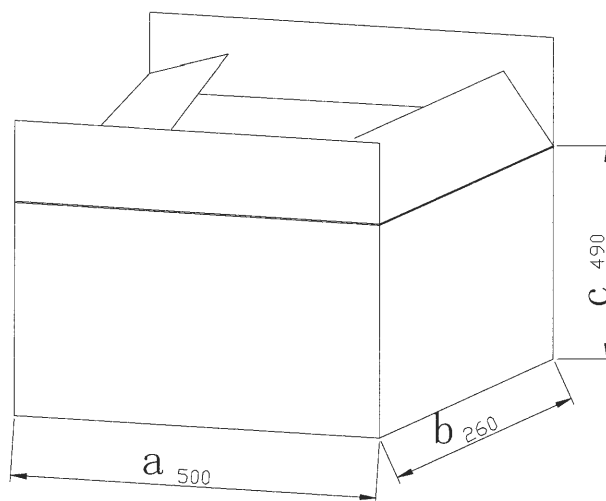

每箱放1000只

		13.01.24	ZhuYu	ShiCong	WangXueWen
Issue No	Description	Date	Issue	Check	Approval

INTERNATIONAL COMPONENTS CORPORATION