

INTERVOX Speakers from International C

215 McCormick Drive, Bohemia, NY 11716 (631) 952-9595 (631) 952-9597 www.icc107.com

1.	MODEL:	S150RS-M			
2.	Dimension	Outer Diameter	36 mm.	Baffle Opening	32.5 mm.
		Height	Refer to Drawing	Weight	7.5 Grams.
3.	Magnet	Materials	Rare Earth	Size	∅ 11.5X 1.5 mm.
4.	Nominal Impedance	8 Ω	± 15 %	At	1200 Hz.
5.	Power Rating	Normal	200 mW.	Maximum	500 mW.
6.	Lowest Resonant Frequency	450	± 20 %		Hz.
7.	Output Sound Pressure Level (S.P.L.)	80 ± 3 db / 0.2 Watt · 0.5 Meter.			
		Average at 800, 1000, 1200, 1500 Hz.			
8.	Frequency Range	300 - 12000 Hz.		Average SPL - 10 db.	
9.	Distortion	5 % Maximum At 1000 Hz. 200 mW.			
10.	Abnormal Sound Test	Must Be Normal Test By 1.3 Volts. Sine Wave.			
11.	Load Test	White Noise With Weighted Filter 1.3 Volts.(RMS) 24 Hrs.			
12.	Polarity	Diaphragm shall move Forward when Apply a Positive DC.			
		Current to the "+" or "Marked" Terminal.			

MOUNTING NOTICE

AT LEAST
0.8mm
FOR
DIAPHRAGM
MOVING

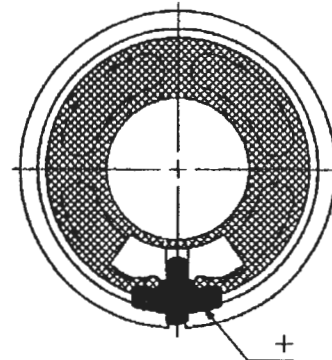
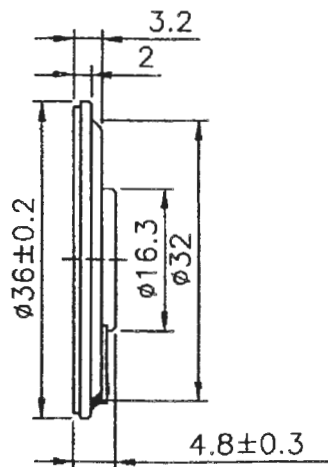
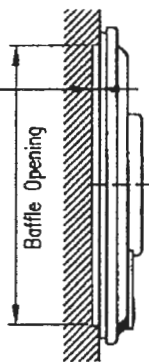

450

Unit : mm

Housing Material : METAL

INTERVOX Speakers from International ©

S150RS-M

450

VOL:1.265V(0.2W) DIS:0.5M

X:1.0000kHz

*Y:81.07dB

ZA:Live Curve

SSR Fund.

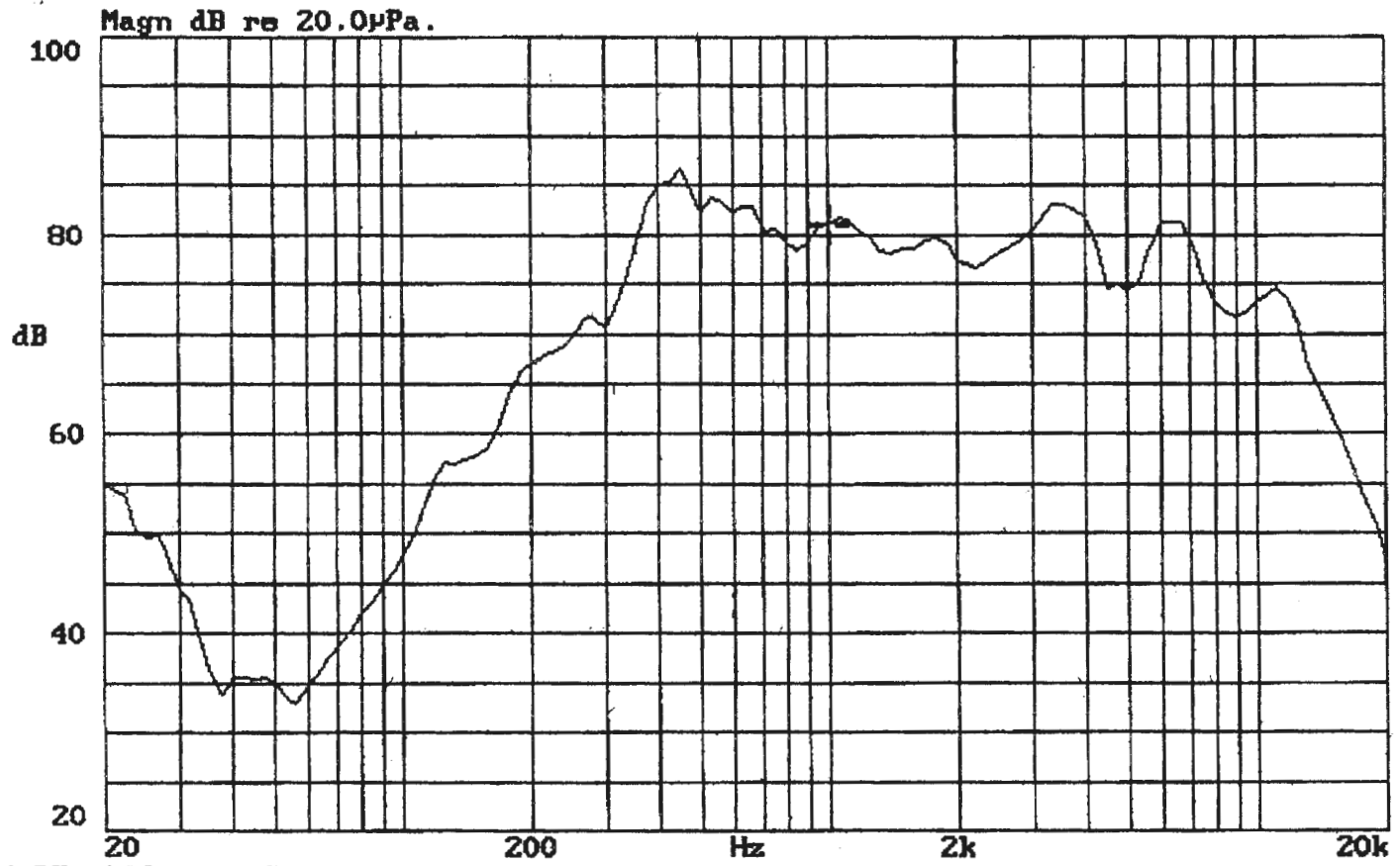

04-DEC-2001 10:43:58

Mode: SSR

