

INTERVOX Speakers from International ©

215 McCormick Drive, Bohemia, NY 11716 (631)952-9595 ♦ Fax: (631) 952-9597 ♦ e-mail: oemsales@icc107.com

Code No. G50

1.	MODEL:	S150RS-M-R5W (RoHS Compliant)	
2.	Dimension & Weight	Outer Diameter 36 mm	Baffle Opening 32.5 mm
		Height Refer to drawing	Weight 7.5 Grams
3.	Magnet	Materials Rare Earth	Size φ 12.5 × 1.5 mm
4.	Nominal Impedance	8 Ω ± 15 %, At 1000 Hz.	
5.	Power Rating	Normal 0.5 Watts	Maximum 1.0 Watts Sine Wave.
6.	Resonant Frequency	500 ± 20 % Hz.	
7.	Output Sound Pressure Level (S.P.L.)	85 ± 3 db/ 0.5 Watt • 0.5 Meter	
		Average at 600, 800, 1000, 1200 Hz.	
8.	Frequency Range	300 ~ 6,000 Hz. Average SPL -10 db.	
9.	Distortion	5 % Maximum At 1000 Hz. 0.5 W.	
10.	Abnormal Sound test	Must be Normal Tested By 2.0 Volts. Sine Wave.	
11.	Load Test	White Noise 2.0 Volts. (RMS.) 24 Hours.	
12.	Polarity	Diaphragm shall move Forward while Apply a Positive DC Signal to the "+" or "Marked" Terminal.	

MOUNTING NOTICE

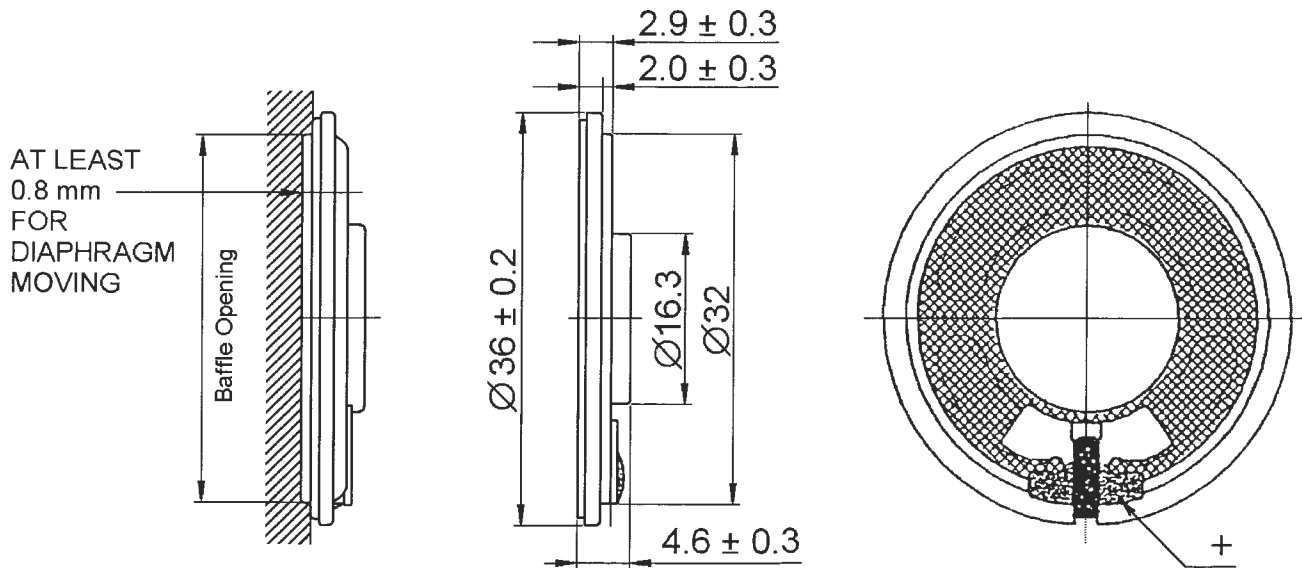

Housing Material: METAL

Unit: mm

Revised 3/04/2004

INTERVOX Speakers from International ©

215 McCormick Drive, Bohemia, NY 11716 (631) 952-9595 • Fax: (631)952-9597 • e-mail: oemsales@icc107.com

S150RS-M-R5W VOL:2.0V[0.5W] DIS:0.5M

Magn dB re 20.0 μ V/V

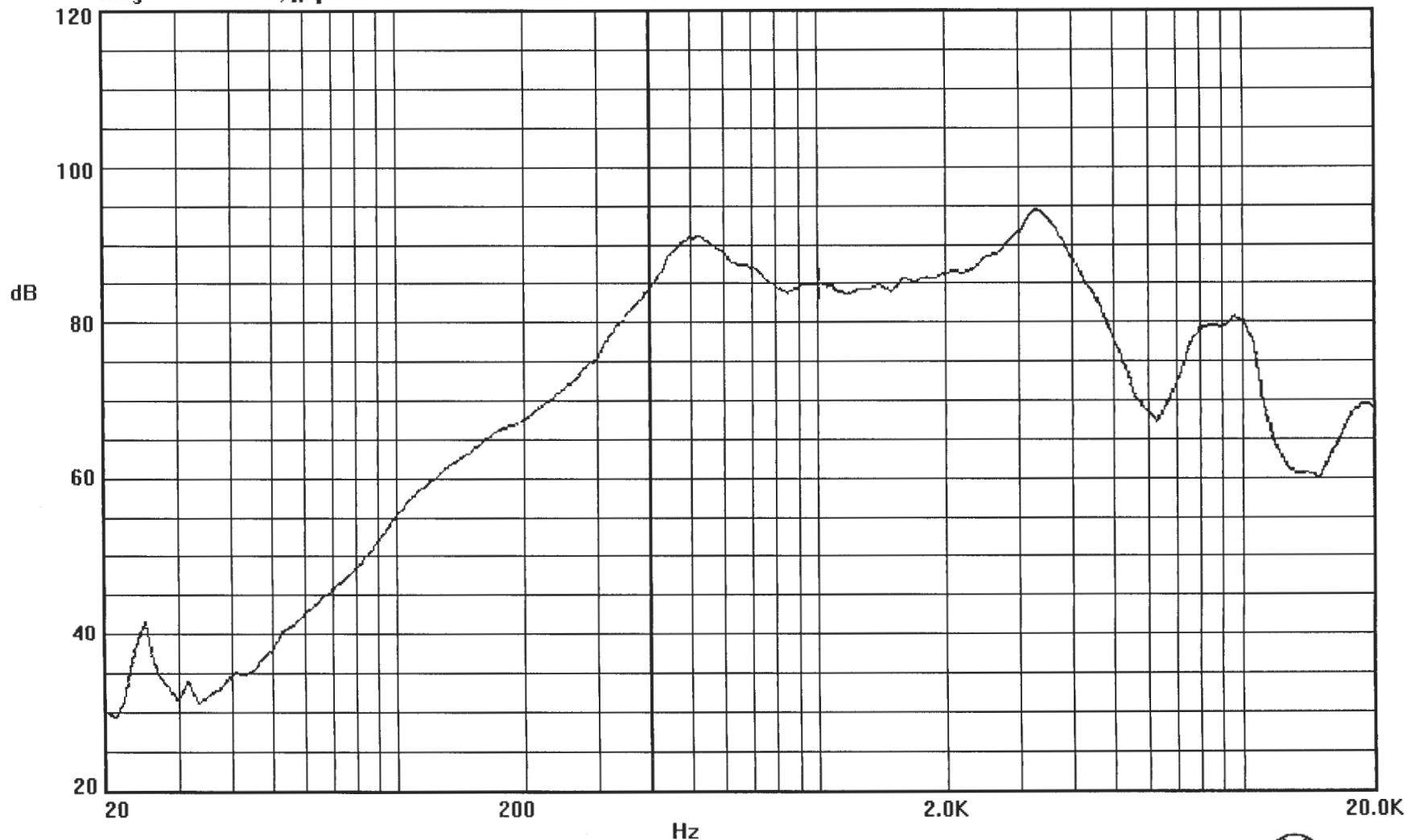

Current Curve: 0 X: 1000 Hz Y: 84.61 dB

Time[Y/M/D H:M:S]: 2003/10/31 15:58:58

Mode: SSR

