

INTERVOX Speakers from International C

215 McCormick Drive, Bohemia, NY 11716 (631) 952-9595 (631) 952-9597 www.icc107.com

1.	MODEL:	S160RMS-B			
2.	Dimension	Outer Diameter	40 mm.	Baffle Opening	38.4 mm.
		Height	Refer to Drawing	Weight	6.8 Grams.
3.	Magnet	Materials	Rare Earth	Size	∅ 12.5x1.5 mm.
4.	Nominal Impedance	8 Ω	± 15 %	At	1000 Hz.
5.	Power Rating	Normal	500 mW.	Maximum	1000 mW.
6.	Lowest Resonant Frequency	420	± 20 %		Hz.
7.	Output Sound Pressure Level (S.P.L.)	87 ± 3 db / 0.5 Watt · 0.5 Meter.			
		Average at	800,	1000,	1200,
8.	Frequency Range	250	~ 5500 Hz.	Average SPL -	10 db.
9.	Distortion	5 %	Maximum At	1000 Hz.	500 mW.
10.	Abnormal Sound Test	Must be Normal Tested By		2.0 Volts.	Sine Wave.
11.	Load Test	White Noise with Weighted Filter		2.0 Volts.(RMS)	24 Hrs.
12.	Polarity	Diaphragm shall move Forward when Apply a Positive DC.			
		Current to the '+' or 'Marked' Terminal.			

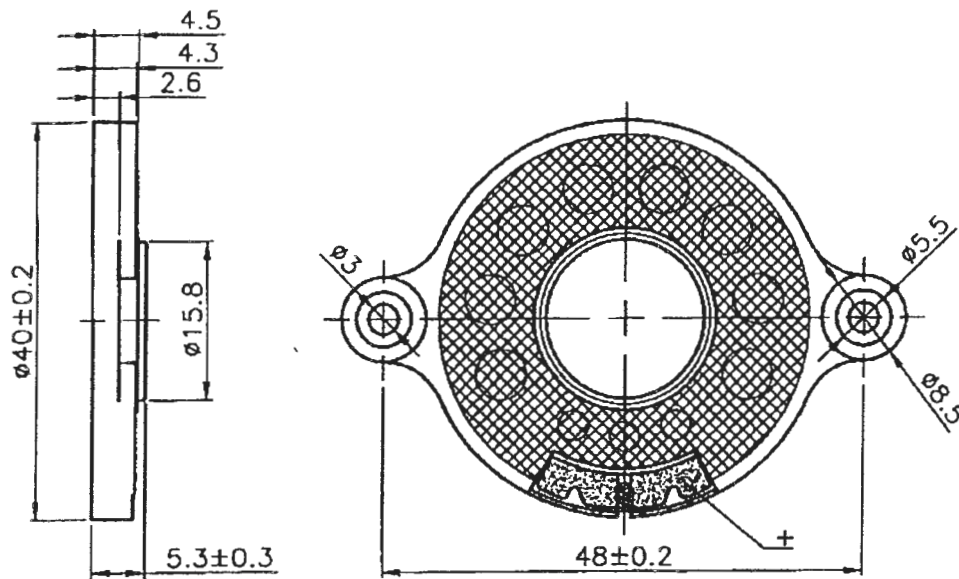

450

Unit : mm

Housing Material : ABS+20%FG

INTERVOX Speakers from International ©

S160RMS-B

450

VOL:2.00(0.5W) DIS:0.5M

X:1.0000kHz

*Y:86.45dB

ZA:1.0000

SSR Fund.

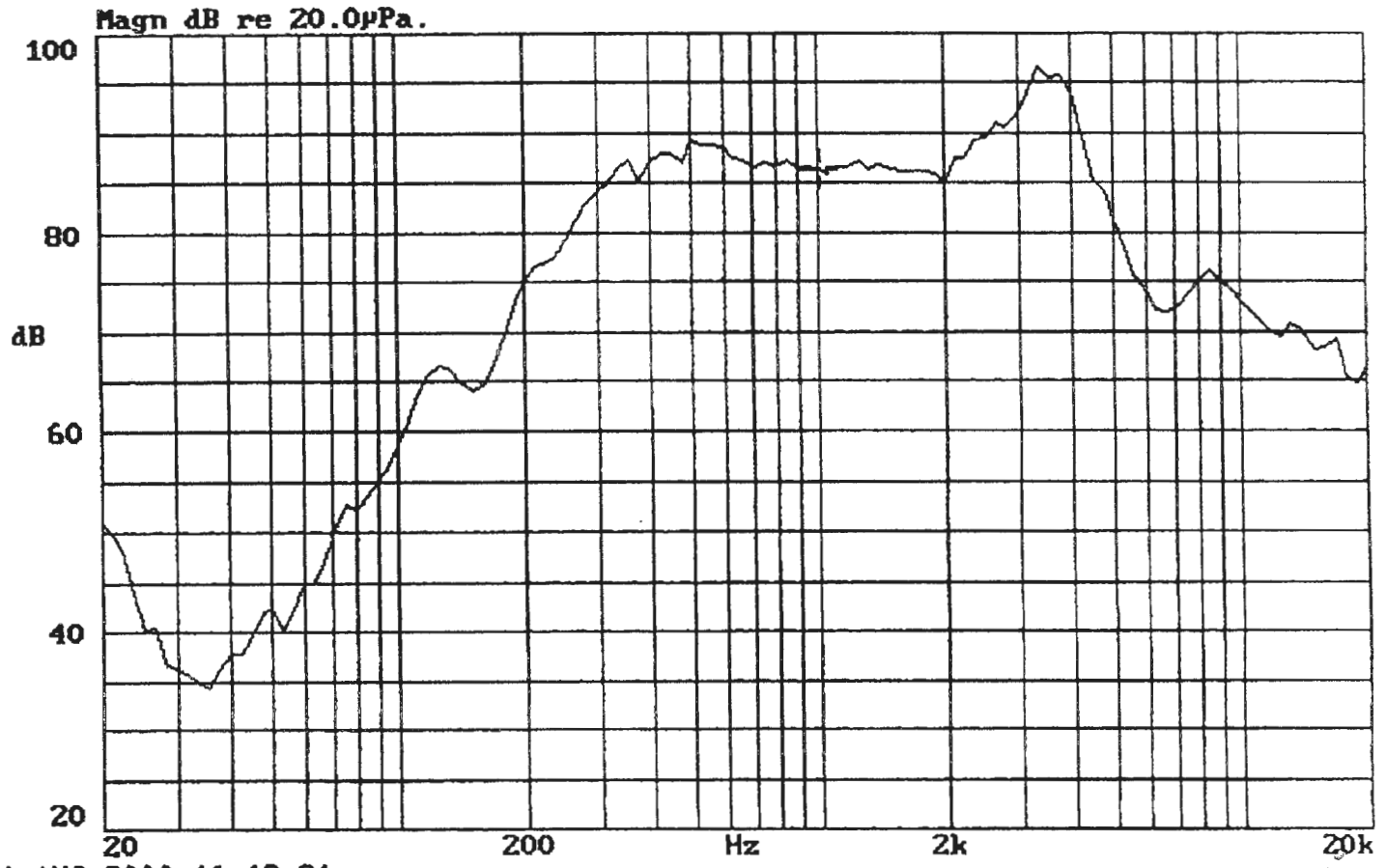

11-AUG-2000 16:19:21

Mode: SSR

