

INTERVOX Speakers from International ©

215 McCormick Drive, Bohemia, NY 11716 (631)952-9595 Fax: (631) 952-9597 e-mail: oemsales@icc107.com

1.	MODEL:	S160RS-M-R2W
2.	Dimension	Outer Diameter 40 mm. Baffle Opening 35.8 mm. Height Refer to Drawing . Weight 9.2 Grams.
3.	Magnet	Materials Rare Earth . Size ϕ 12.5X 1.5 mm.
4.	Nominal Impedance	8 Ω \pm 15 % At 1000 Hz.
5.	Power Rating	Normal 200 mW. Maximum 400 mW.
6.	Lowest Resonant Frequency	350 \pm 20 % Hz.
7.	Output Sound Pressure Level (S.P.L.)	83 \pm 3 db / 0.2 Watt . 0.5 Meter. Average at 800, 1000, 1200, 1500 Hz.
8.	Frequency Range	200 ~ 6000 Hz. Average SPL - 10 db.
9.	Distortion	5 % Maximum At 1000 Hz. 200 mW.
10.	Abnormal Sound Test	Must be Normal Tested By 1.3 Volts. Sine Wave.
11.	Load Test	White Noise with Weighted Filter 1.3 Volts.(RMS) 24 Hrs.
12.	Polarity	Diaphragm shall move Forward when Apply a Positive DC. Current to the "+" or "Marked" Terminal.

MOUNTING NOTICE

AT LEAST
0.8mm
FOR
DIAPHRAGM
MOVING

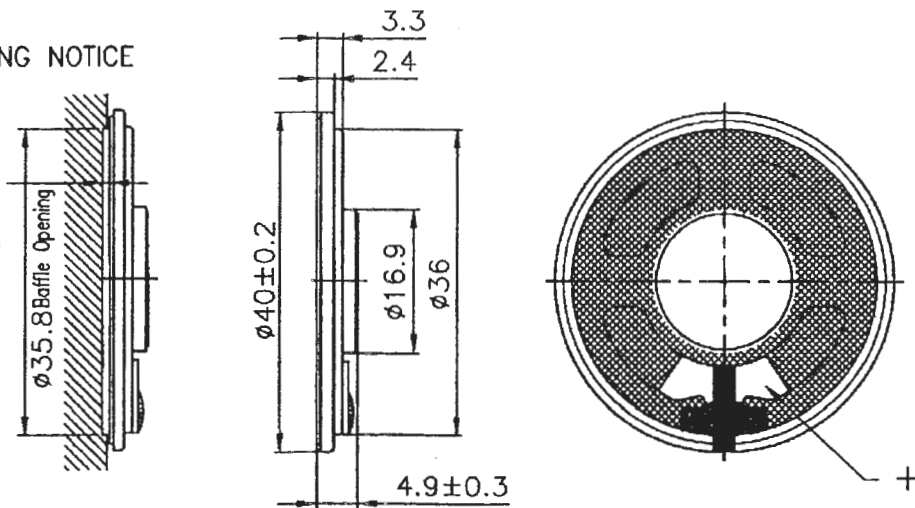

450

Unit : mm

Housing Material : METAL

INTERVOX Speakers from International ©

S160RS-M-R2W

450

VOL:1.265V(0.2W) DIS:0.5M

X:1.0000kHz

*Y:81.96dB

ZA:1.0000

SSR Fund.

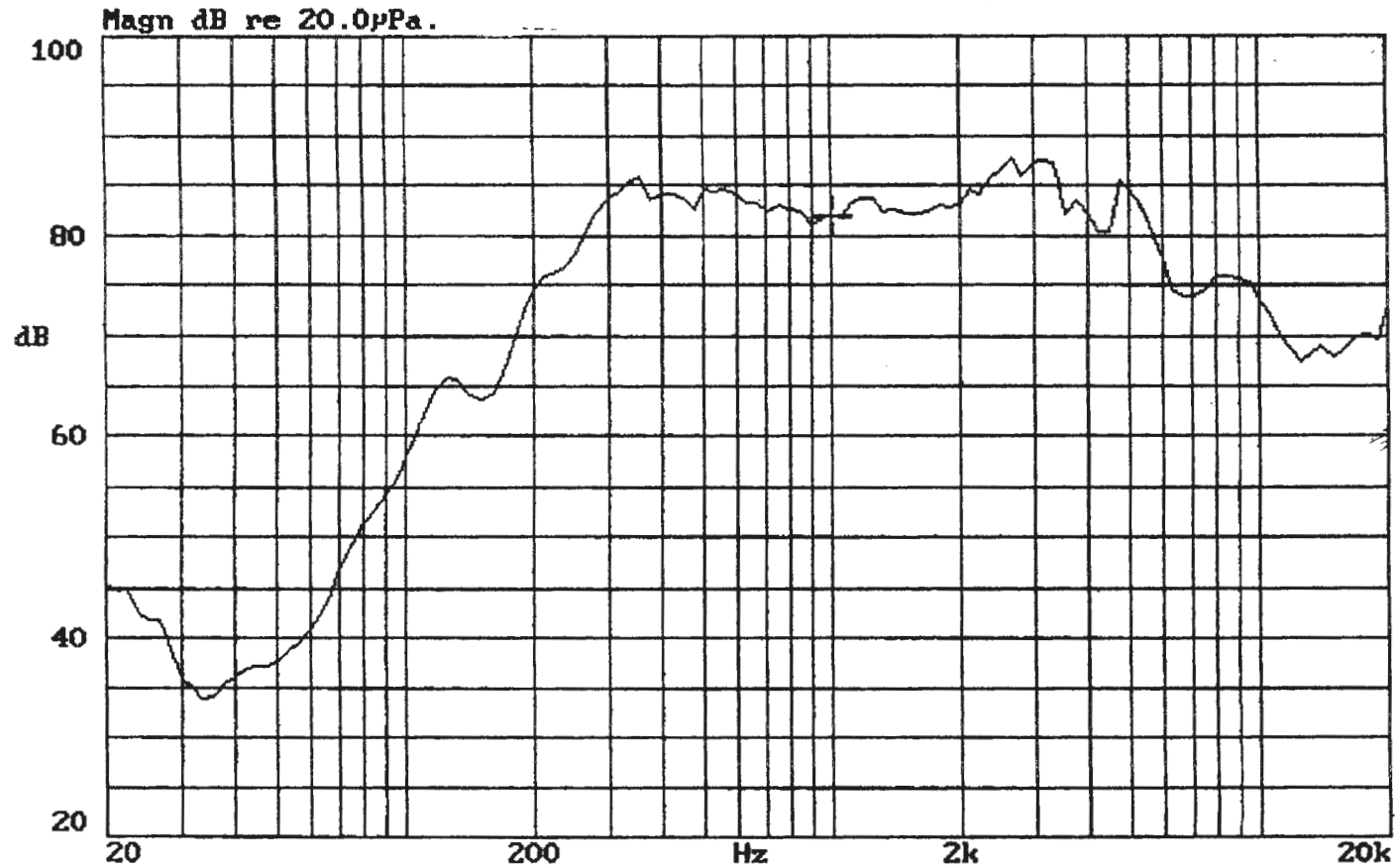

26-MAY-2000 10:18:30

Mode: SSR

