

INTERVOX Speakers from International C

215 McCormick Drive, Bohemia, NY 11716 (631) 952-9595 (631) 952-9597 www.icc107.com

1.	MODEL:	S160SL
2.	Dimension	Outer Diameter 40 mm. Baffle Opening 37.5 mm.
		Height Refer to Drawing. Weight 10.4 Grams.
3.	Magnet	Materials Rare Earth. Size ϕ 12.5X1.5 mm.
4.	Nominal Impedance	8 Ω \pm 15 % At 1200 Hz.
5.	Power Rating	Normal 200 mW. Maximum 300 mW.
6.	Lowest Resonant Frequency	550 \pm 20 % Hz.
7.	Output Sound Pressure Level (S.P.L.)	80 \pm 3 db / 0.2 Watt - 0.5 Meter.
		Average at 800, 1000, 1200, 1500 Hz.
8.	Frequency Range	300 - 6700 Hz. Average SPL - 10 db.
9.	Distortion	5 % Maximum At 1000 Hz 200 mW.
10.	Abnormal Sound Test	Must Be Normal Test By 1.3 Volts. Sine Wave.
11.	Load Test	White Noise With Weighted Filter 1.3 Volts.(RMS) 24 Hrs.
12.	Polarity	Diaphragm shall move Forward when Apply a Positive DC.
		Current to the "+" or "Marked" Terminal.

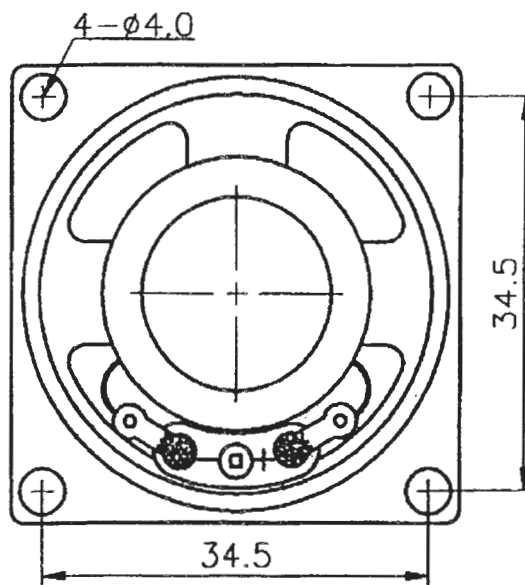
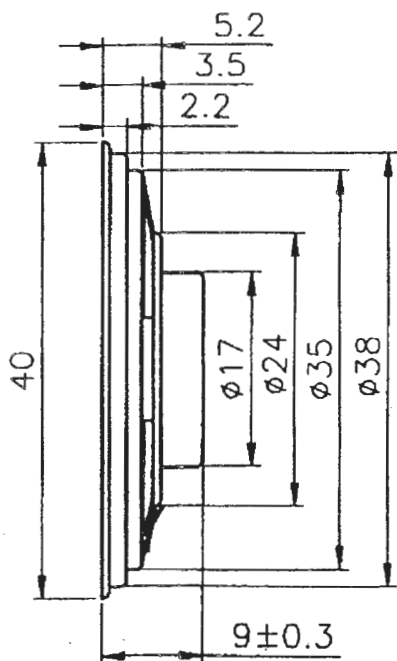

INTERVOX Speakers from International ©

S160SL

450

Vol:1.265V(0.2W) Dis:0.5M

X:1.0000kHz

*Y:80.16dB

ZA:1.0000

SSR Fund.

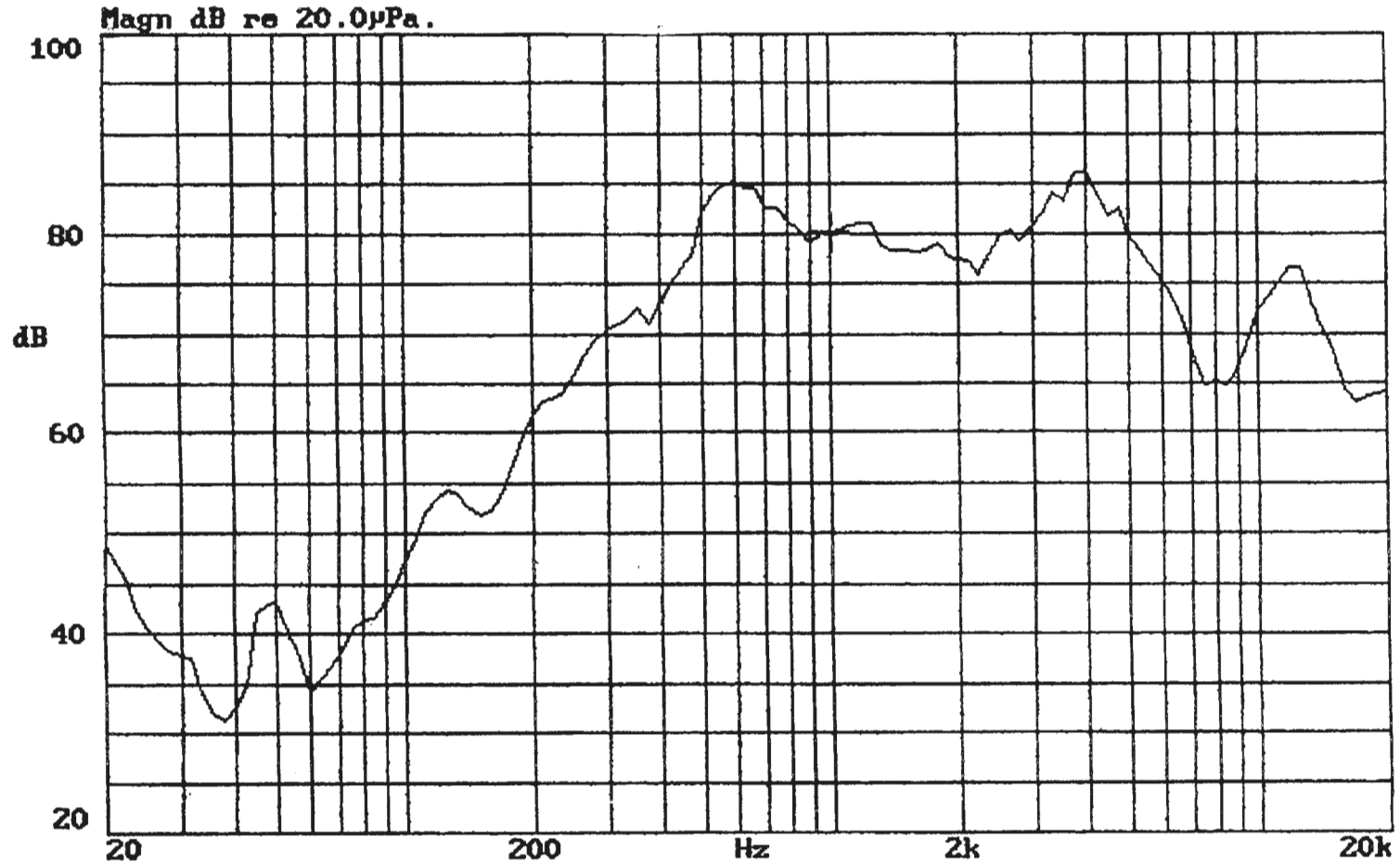

28-JUN-1999 16:52:27

Mode: SSR

