

INTERVOX Speakers from International C

215 McCormick Drive, Bohemia, NY 11716 (631) 952-9595 (631) 952-9597 www.icc107.com

1.	MODEL:	S200SL			
2.	Dimension	Outer Diameter	50 X 50 mm.	Baffle Opening	44.2 mm.
		Height	Refer to Drawing .	Weight	12.8 Grams.
3.	Magnet	Materials	Rear Earth	Size	∅ 12.5X1.5 mm.
4.	Nominal Impedance	8 Ω	± 15 %	At	1200 Hz.
5.	Power Rating	Normal	300 mW.	Maximum	600 mW.
6.	Lowest Resonant Frequency	480	± 20 %		Hz.
7.	Output Sound Pressure Level (S.P.L.)	81	± 3 db /	0.3 Watt ·	0.5 Meter.
		Average at	800, 1000, 1200, 1500		Hz.
8.	Frequency Range	250	~ 6000 Hz	Average SPL -	10 db.
9.	Distortion	5 %	Maximum At	1000 Hz	300 mW.
10.	Abnormal Sound Test	Must Be Normal Test By 1.6 Volts. Sine Wave.			
11.	Load Test	White Noise With Weighted Filter 1.6 Volts.(RMS) 24 Hrs.			
12.	Polarity	Diaphragm shall move Forward when Apply a Positive DC.			
		Current to the "+" or "Marked" Terminal.			

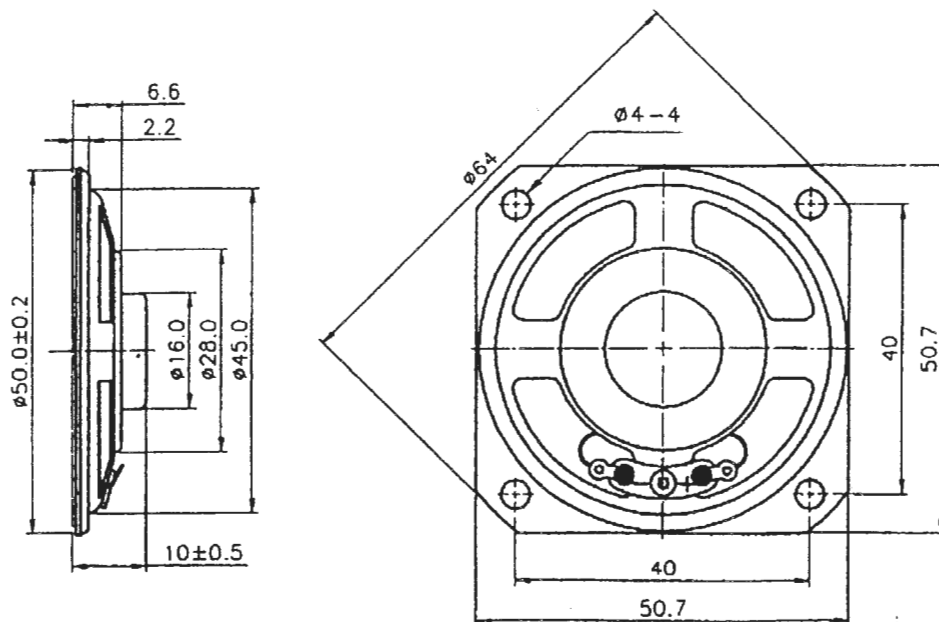

450

Unit : mm

Housing Material : METAL

INTERVOX Speakers from International ©

S200SL

450

VOL:1.549V(0.3W) DIS:0.5M

X:1.000kHz

*Y:80.87dB

ZA:Live Curve

SSR Fund.

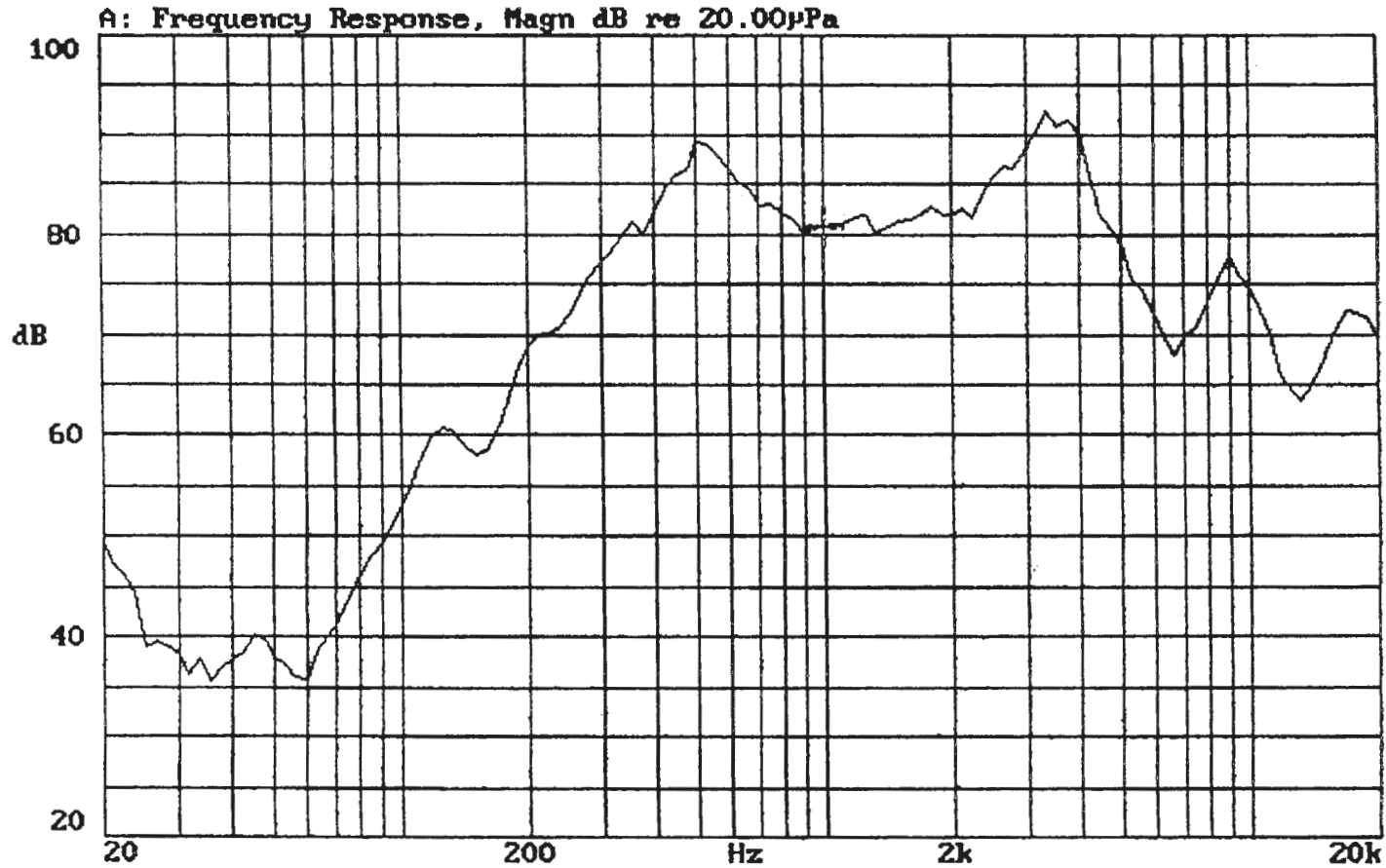

06-JUL-1999 15:10:14

Mode: SSR

