

# INTERVOX Speakers from **International C**

215 McCormick Drive, Bohemia, NY 11716 (631) 952-9595 (631) 952-9597 www.icc107.com

ICC Part No.	<b>S300RA</b>	
1. Voice Coil Imp.	$8 \Omega \pm 15\%$	At 1000 Hz 1 Volt
2. Operation	Must be normal	Program Source 0.5W
3. Buzz & Rattles	Must be normal	Sin Wave 0.5W
4. Resonant Freq.	$250 \pm 50$ Hz	Without Baffle
5. Output S.P.L.	$90 \pm 3$ dB/W Mean Value at 0.5, 0.6, 0.8, 1.0 KHz	From 50cm Measurement 0.5W
6. Freq. Response	FO ~ 5000 Hz $\pm 10$ dB	
7. Rated Freq. Response	Hz	
8. Rated Power Input	0.25W	
9. Max. Power Input	0.5W	
10. Load Test	After Test Meet Items 2 & 3	White Noise 0.25W 96 Hours
11. Heat Test	After Test Meet Items 2 & 3	$40^\circ \pm 2^\circ$ C 50% R.H. 96 Hours
12. Humidity Test		$40^\circ \pm 2^\circ$ C 90% R.H. 96 Hours
13. Distortion	5% Max.	Rated Power Input 1000 Hz
14. Total Flux	Maxwell	
15. Flux Density	6300 Gauss	
16. Magnet	Material: Rare Earth	Size: 13 x 10mm Weight: .35 oz.
17. Total Weight	1.98 oz.	
18. Baffle Opening	70mm	
19. Outside Diameter	77 x 77mm	(Eliminate Rim: 71.3mm)
20. Total Height	25mm	
21. Yoke Size	22 x 14.2 x 12.5mm	Outside Diameter of Seat: 36.5mm
22. Mounting Diameter	85.5mm	

# INTERVOX Speakers from International ©

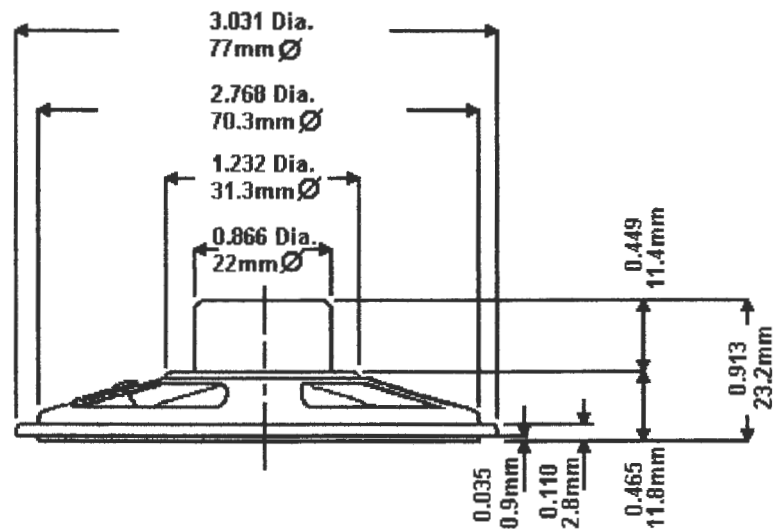
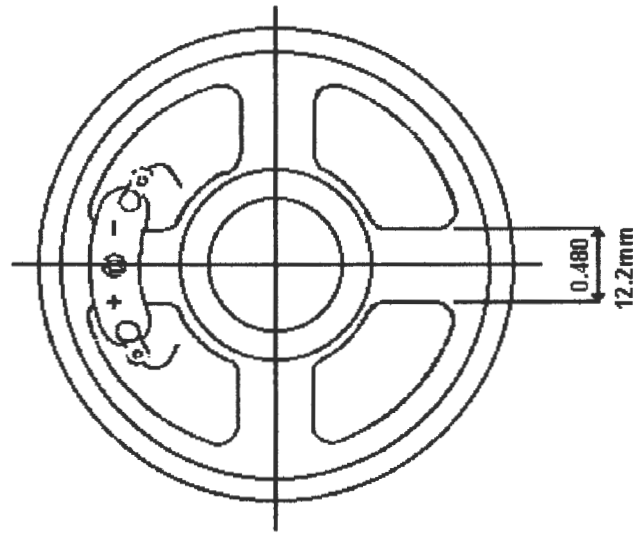

Part No.: S300RA	All Tolerances: Inch $\pm$ 0.012 mm $\pm$ 0.3
Size: 77mm 3"	

# INTERVOX Speakers from International ©

Measuring Object: S300RA

Measuring Condition: 2 V 0.5 W 0.5 M

Level Range: 60 dB Zero Level (Fundamental) : 60 dB X Axis Speed: 23 mm/sec

Impedance Range:          Ω Zero Level (Harmonic) :          dB Y Axis Speed: 1000 mm/sec

