

INTERVOX Speakers from International ©

215 McCormick Drive, Bohemia, NY 11716 Tel: (631) 952-9595 Fax: (631) 952-9597 www.icc107.com

No. 215

ICC Part No.	S400RA	
1. Voice Coil Imp.	$8 \Omega \pm 15\%$	At 800 Hz 1 Volt
2. Operation	Must be normal	Program Source 1W
3. Buzz & Rattles	Must be normal	Sin Wave 1W
4. Resonant Freq.	$200 \pm 20\%$ Hz	Without Baffle
5. Output S.P.L.	91 ± 3 dB/W Mean Value at 0.3, 0.4, 0.5, 0.6 KHz	From 50cm Measurement
6. Freq. Response	FO ~ 14000 Hz ± 10 dB	
7. Rated Freq. Response	Hz	
8. Rated Power Input	0.5W	
9. Max. Power Input	1W	
10. Load Test	After Test Meet Items 2 & 3	White Noise 0.5W 5 Hours
11. Heat Test	After Test Meet Items 2 & 3	$40^\circ \pm 2^\circ$ C 50% R.H. 96 Hours
12. Humidity Test		$40^\circ \pm 2^\circ$ C 90% R.H. 96 Hours
13. Distortion	5% Max.	Rated Power Input 1000 Hz
14. Total Flux	Maxwell	
15. Flux Density	6300 Gauss	
16. Magnet	Material: Rare Earth	Size: 13 x 10mm Weight: .35 oz.
17. Total Weight	2.4 oz.	
18. Baffle Opening	93mm	
19. Outside Diameter	102mm	(Eliminate Rim: 93mm)
20. Total Height	33mm	
21. Yoke Size	22 x 14.2 x 12.5mm	Outside Diameter of Seat: 22mm
22. Mounting	Diameter: 115mm	

INTERVOX Speakers from International ©

215 McCormick Drive, Bohemia, NY 11716 Tel: (631) 952-9595 Fax: (631) 952-9597 www.icc107.com

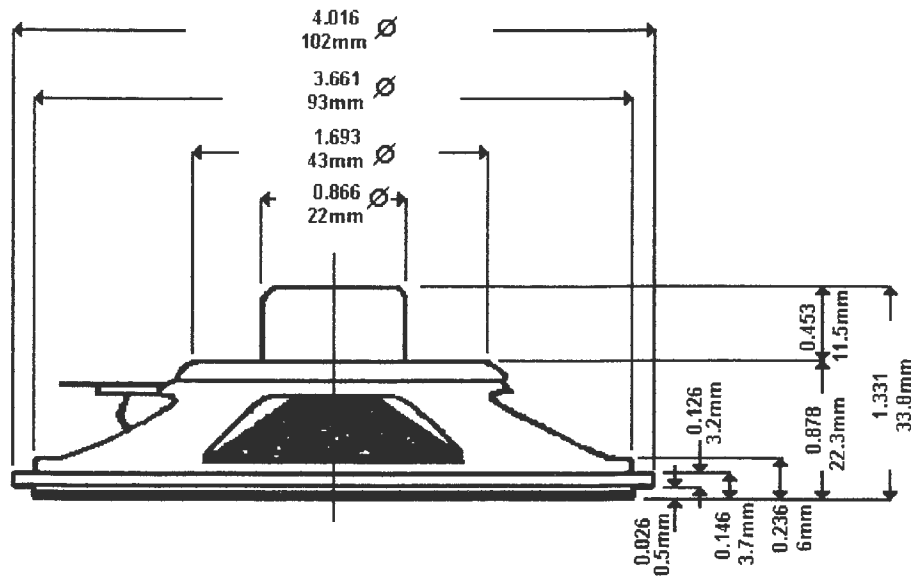
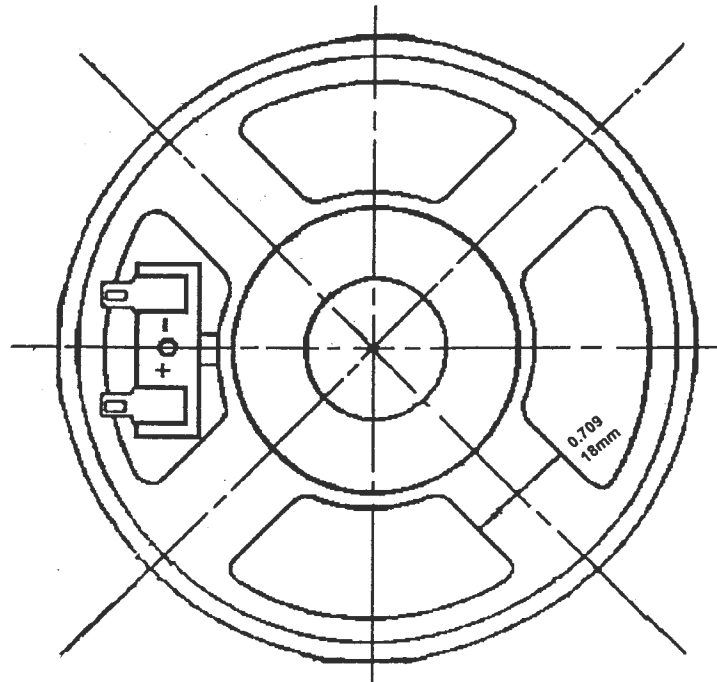

Part No.: S400RA	All Tolerances
Size: 100mm 4"	Inch \pm 0.04 mm \pm 0.1