

SPECIFICATIONS SHEET

PRODUCT TYPE : EXTERNAL DRIVE PIEZO TRANSDUCER

PRODUCT SERIES : BRP1706SM-20

DESCRIPTION : PZ TRANSDUCER 12V SMD PPS SP

1) ADD **YELLOW** WASHING LABEL ON TOP 2) RoHS

COLOR : BLACK

ELECTRICAL SPECIFICATIONS

<u>MODEL NO.</u>	<u>BRP1706SM-20</u>
<u>SOUND PRESSURE LEVEL</u>	90.0 dBA min. (12.0V p-p Square Wave , 10 cm , 4000 Hz)
<u>CAPACITANCE</u>	15000 pF ± 30 % at 120 Hz
* <u>MAX. INPUT VOLTAGE</u>	30.0 V p-p
<u>OPERATING TEMPERATURE</u>	-20 ~ +75 ° C
<u>TERMINAL</u>	SMD
<u>HOUSING MATERIAL</u>	PPS
* <u>WEIGHT</u>	2.0 g

DIMENSIONS

UNIT : mm

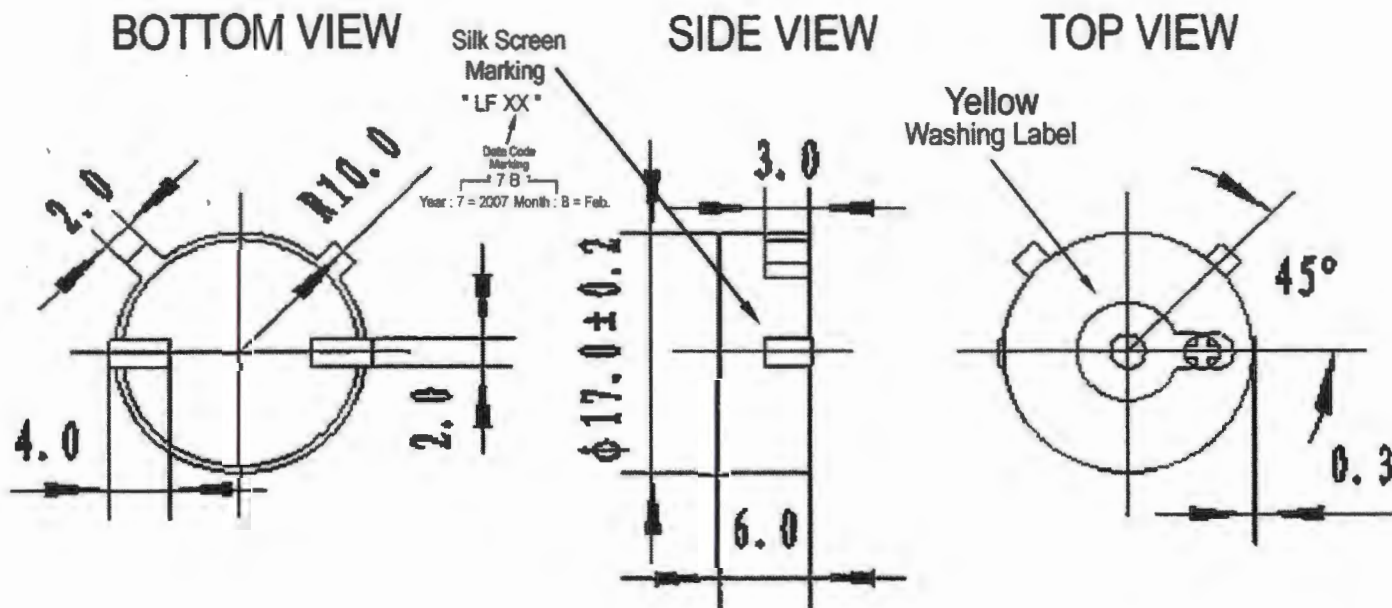

Modify :	Date :	By :
Modify Description " Add Yellow Washing Label " & Draw	05-Feb-07	Joey
		Ref: 2-002

Approved By : ST
Date : 5-Feb.-2007

Prepared By : LL
Date : 5-Feb.-2007

SPECIFICATION FOR ICC/INTERVOX BRP1706SM-20

Tape & Reel Packing

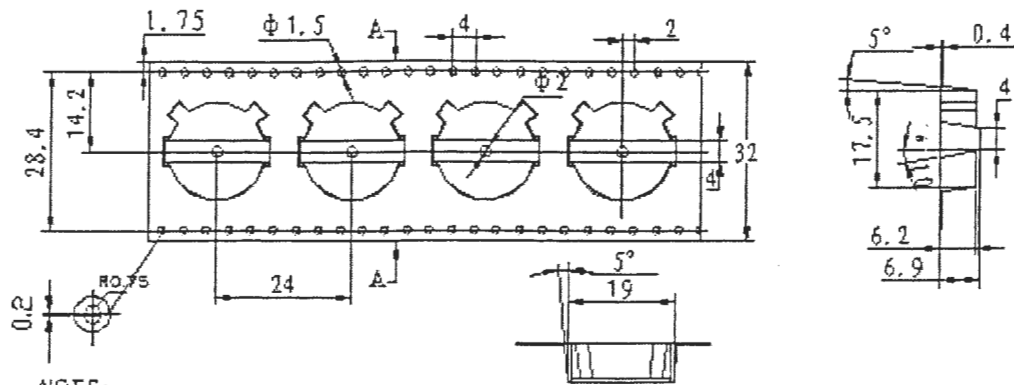

NOTE:

1. 1.0 sprocket hole pitch cumulative tolerance ± 0.2 mm.
2. All dimensions meet EIA-481-D requirements.
3. Thickness: 0.4 ± 0.05 mm.
4. Component loaded per 13" reel: 400 pcs.

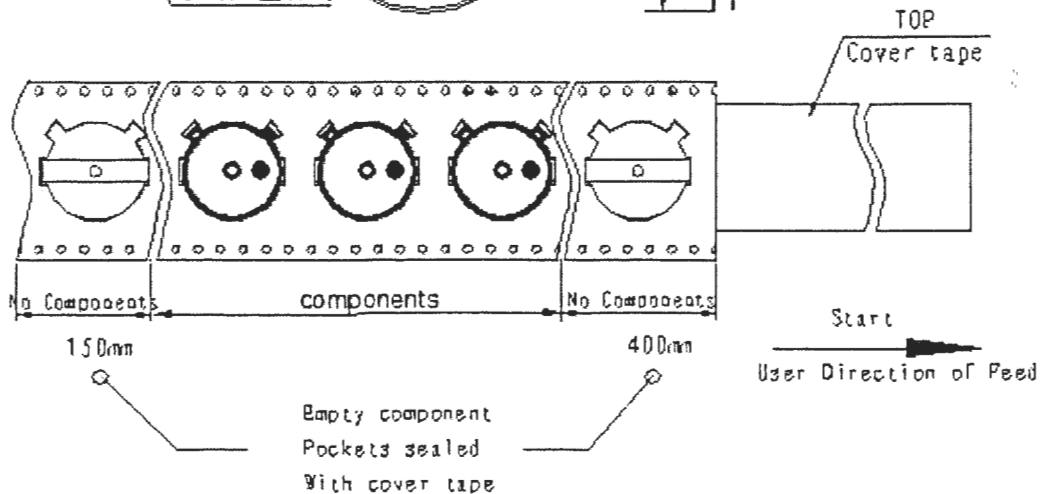
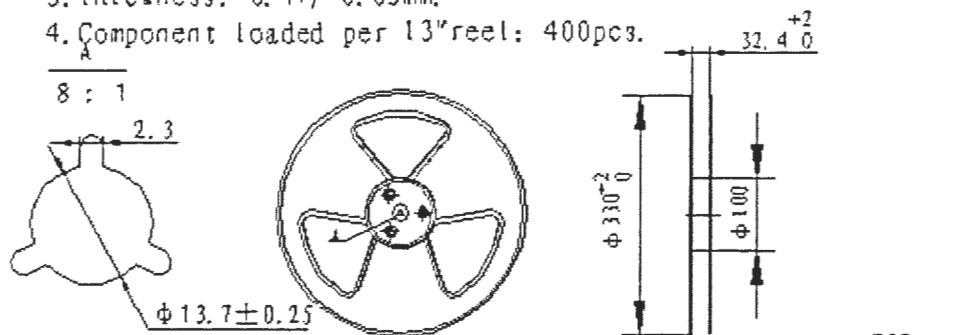

SPECIFICATION FOR ICC/INTERVOX BRP1706SM-20

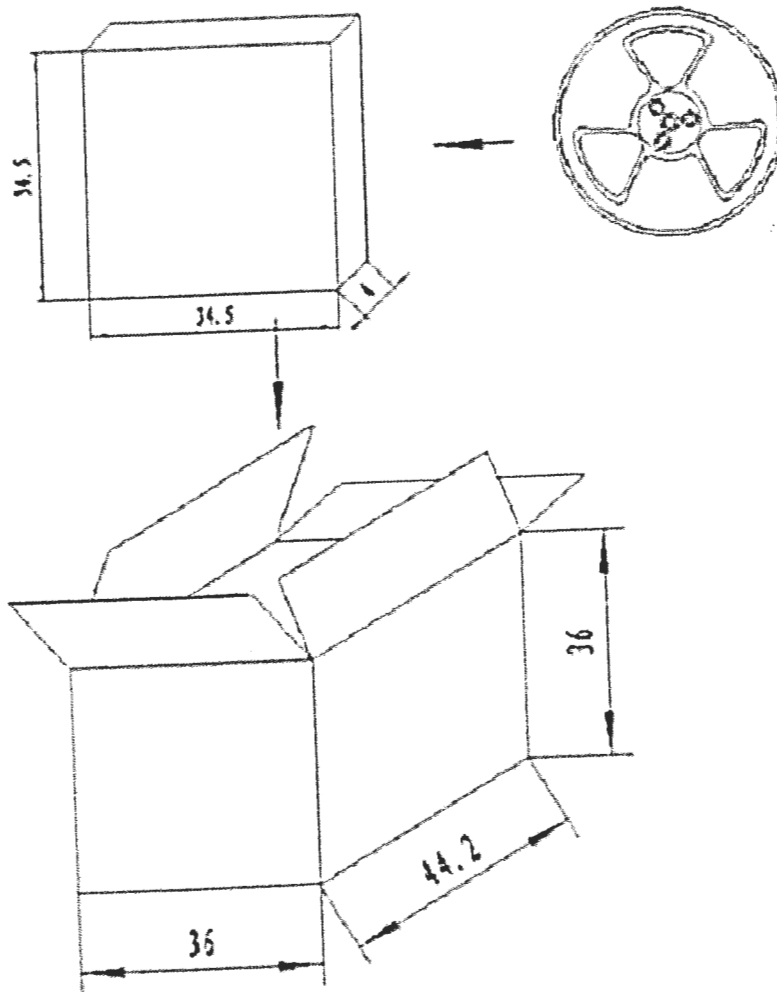

NOTES:

- 1.400 PCS per box
- 2.Total 10 boxes per carton
- 3.Total 4000 PCS carton
- 4.Volume: $36 \times 36 \times 44.5$ cm