



**INTERVOX** Part No: *BST0804SM-03-4T*

**1. Features**

- ◆ Compact  
Small and Slim Size of 8.5mmW×8.5mmL×4.0mmH
- ◆ Low Profile Design
- ◆ For Reflow Process
- ◆ Side Sound Port
- ◆ Tape and Reel Packing
- ◆ RoHS Compliant and Lead Free are Applied

**2. Specification**

No.	Item	Unit	Specification	Condition
1	Rated Voltage	Vp-p	3.6	
2	Operating Voltage Range	Vp-p	2.5~4.5	
3	Current Consumption•	mA	Max 100	at 3.6 Vp-p/Duty 50%
4	Coil Resistance	Ω	16±3	
5	Sound Output at 10Cm•	dB	Min 87	
6	Resonant Frequency	Hz	2,730	
7	Operating Temperature	°C	-30 ~ +70	
8	Storage Temperature	°C	-40 ~ +85	
9	weight	g	Max 0.6	
10	Case Material		LCP(Black)	
11	Dimension	mm		See appearance drawing
12	Terminal		SMD	

• Value applying rated voltage ( 2,730Hz, 1/2 Duty, Square wave )

**3. Measurement Setup**

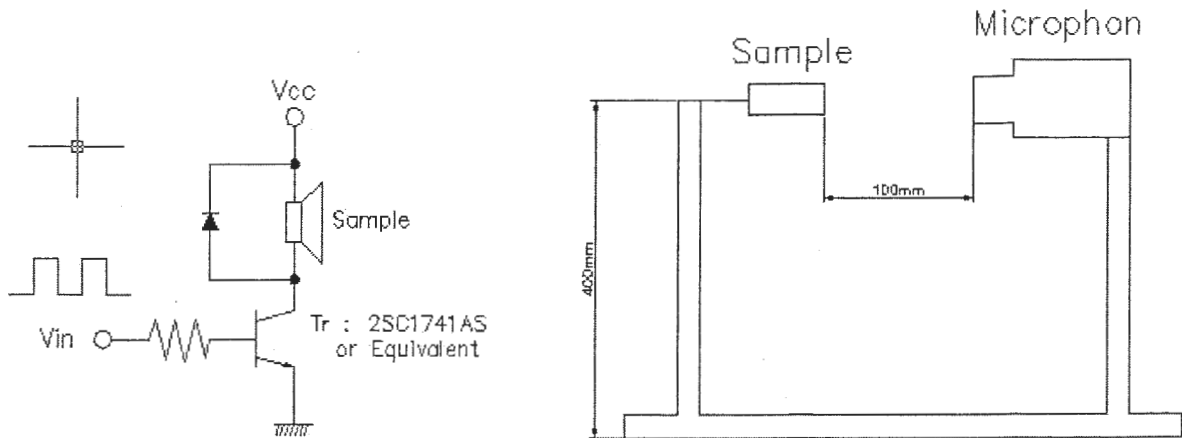

( Standard Drive Circuit )

**4. Frequency Response**

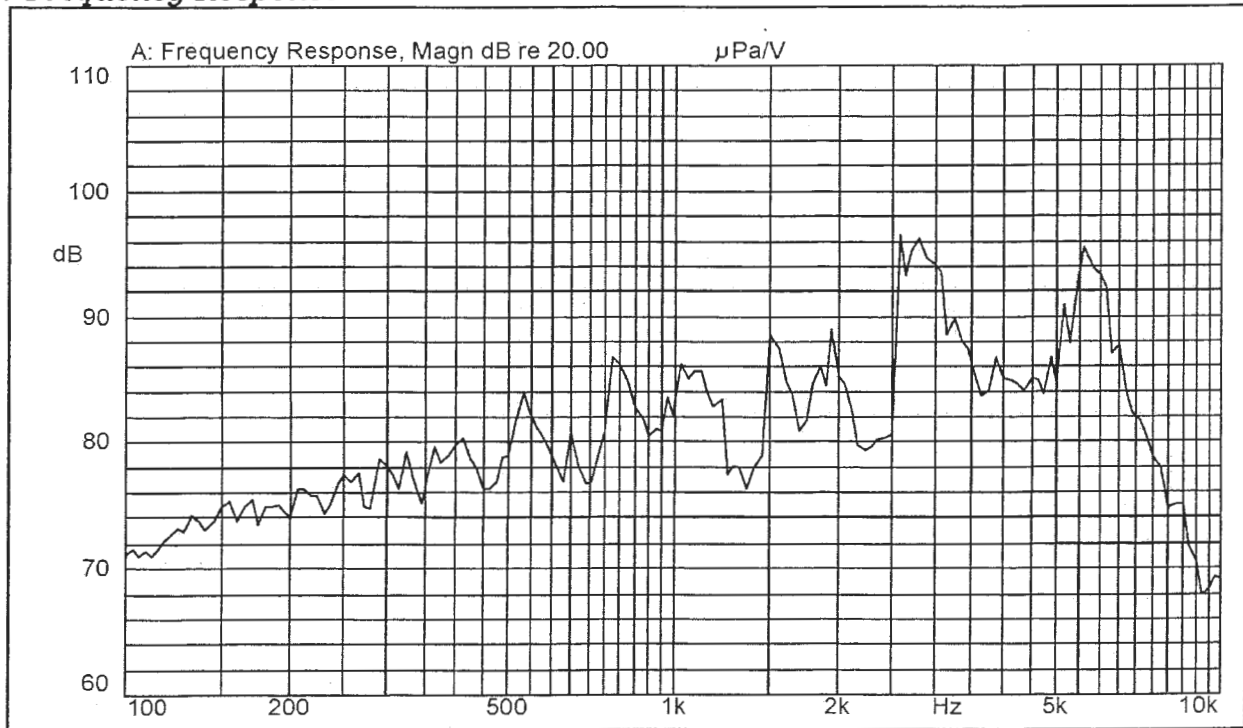

MODEL NO. : BST0804SM-03-4T

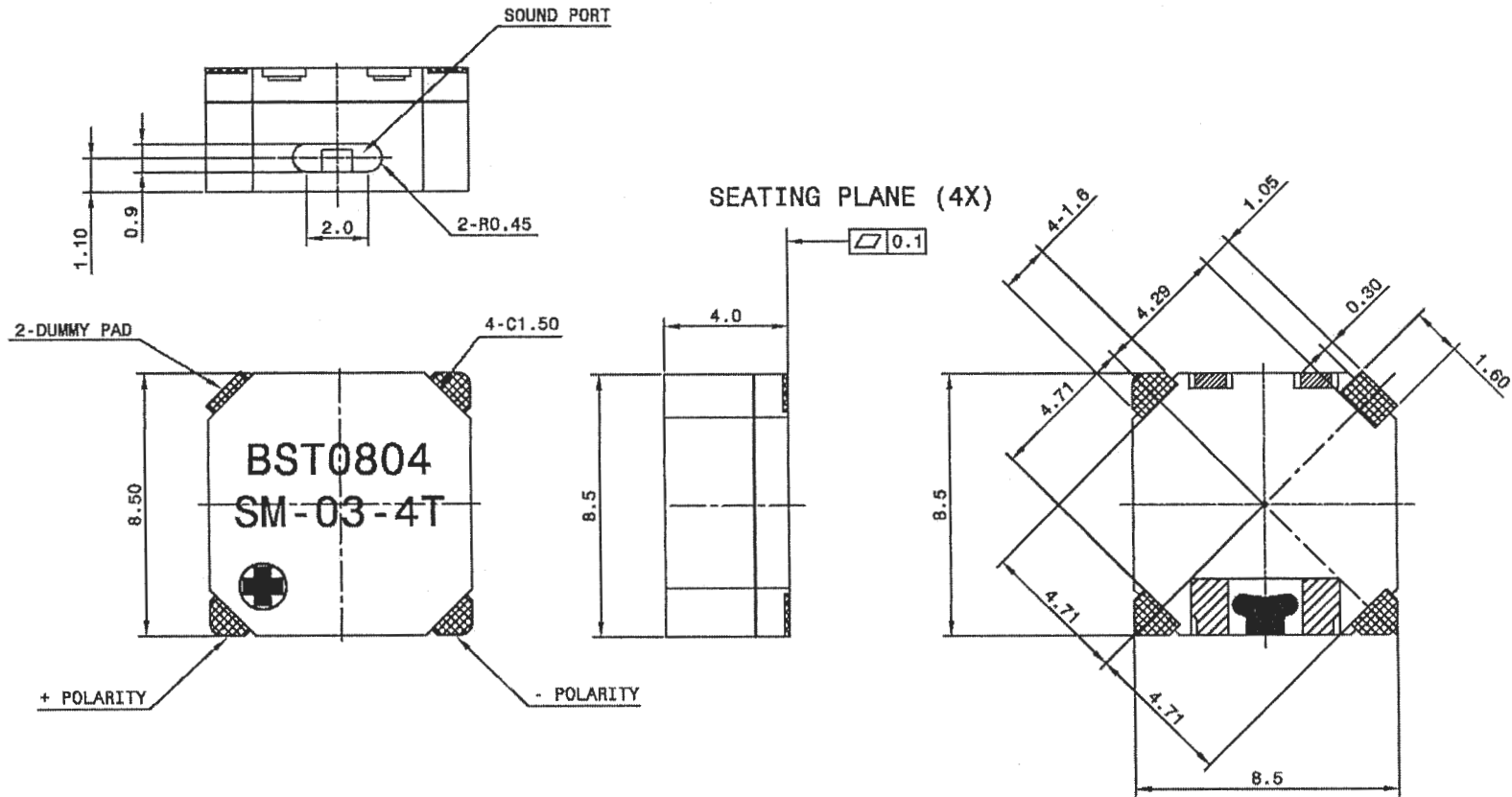

UNIT : mm  
TOLERANCE :  $\pm 0.2$   
MATERIAL : LCP

Unit [mm]

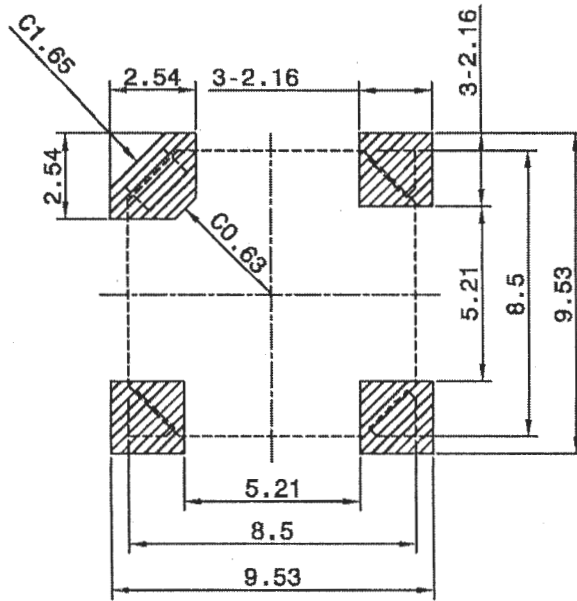



RECOMMENDED LAND PATTERN DIMENSIONS

MODEL:BST0804SM-03-4T

1 REEL

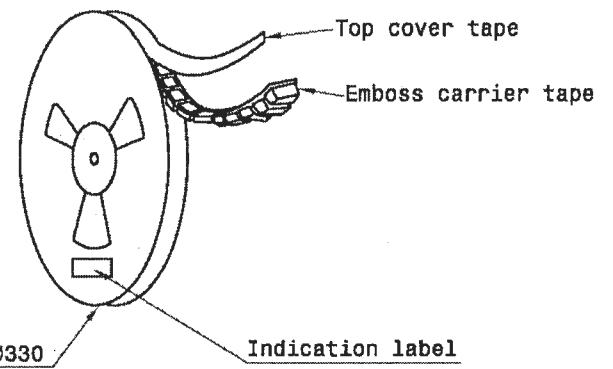
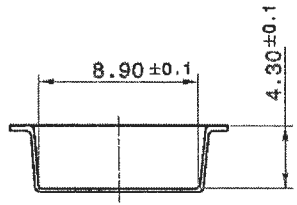
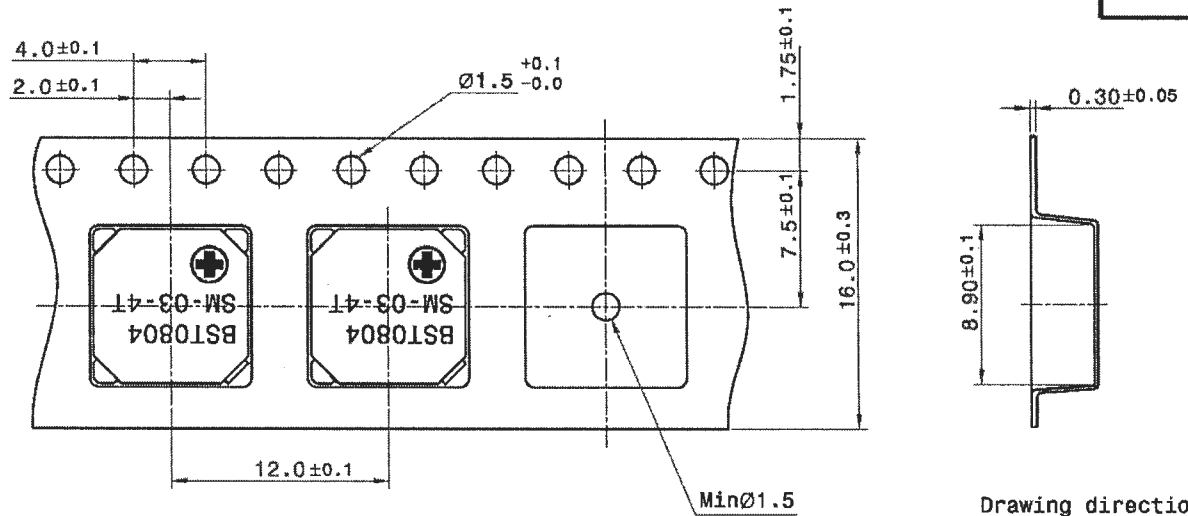
1000PCS



4						승인 APPROVED		재질 MATERIAL		작성일자 DATE	2003.06.23	
3						검도 CHECKED		표면처리 FINISH				
2						설계 DESIGNED		부품명 PART NAME		제품명 MODEL NAME	BST0804SM-03-4T	
1						일반공차 TOLERANCE	±0.05	UNIT : mm				
NO.	년월일 DATE	변경번호 CHANGE NO.	변경내용 CHANGE CONTENTS			설계 DESIGNED	검도 CHECKED	승인 APPROVED	제3각법 SCALE	5/1	 <small>A Division of International Components Corp.</small>	

# Lead Free Reflow profile

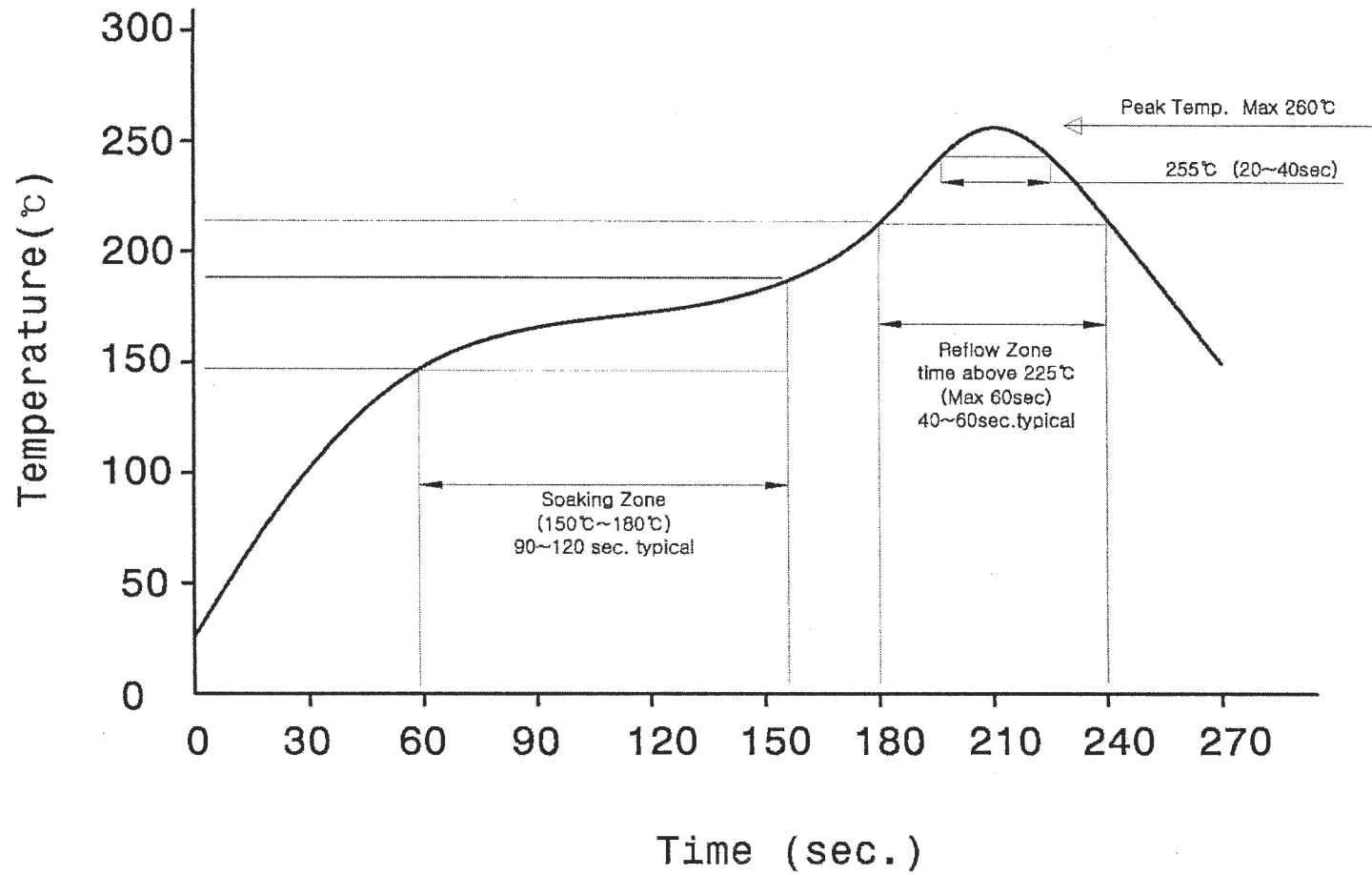

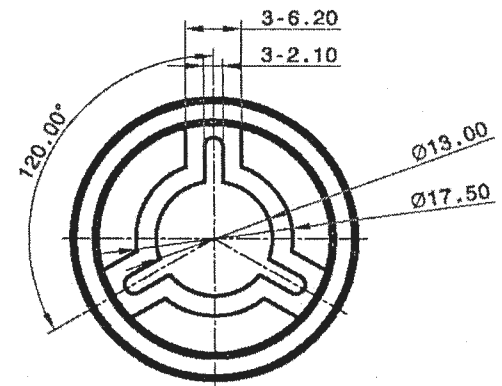
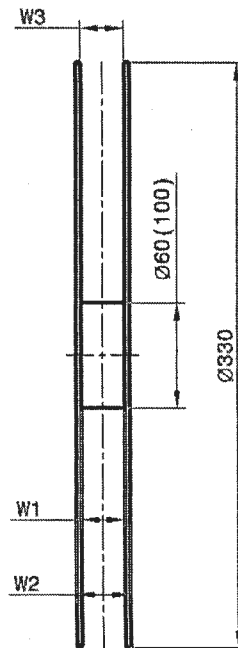
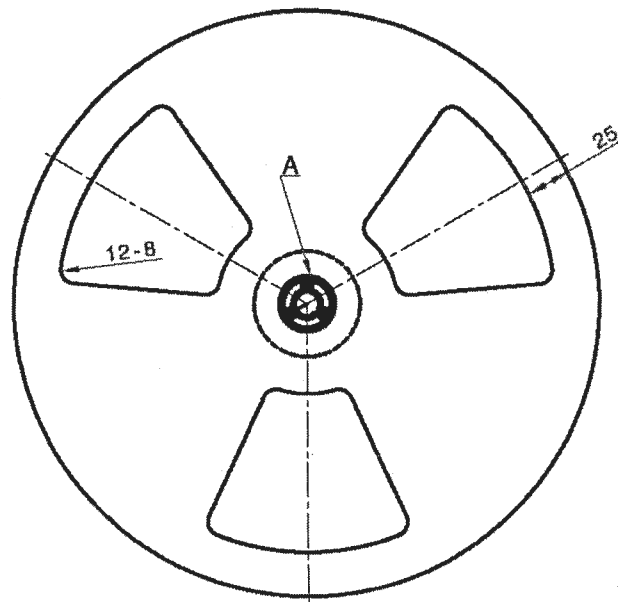

DETAIL A (S=NS)

NORMAL WIDTH	W1 +2 -0	W2 MAX	W3 +3 -0.5
16mm	16.4	22.4	16.4
24mm	24.4	30.4	24.4

4							승인 APPROVED	재질 MATERIAL	PS	작성일자 DATE	1999.03.15
3							검도 CHECKED	표면처리 FINISH		도번 DRAWING NO.	
2							설계 DESIGNED	부품명 PART NAME		제품명 MODEL NAME	REEL
1							일반공차 TOLERANCE	±0.05	UNIT : mm		
NO.	년월일 DATE	수정번호 CHANGE NO.	수정내용 CHANGE CONTENTS	설계 DESIGNED	검도 CHECKED	승인 APPROVED	제3각법	척도 SCALE	NS		

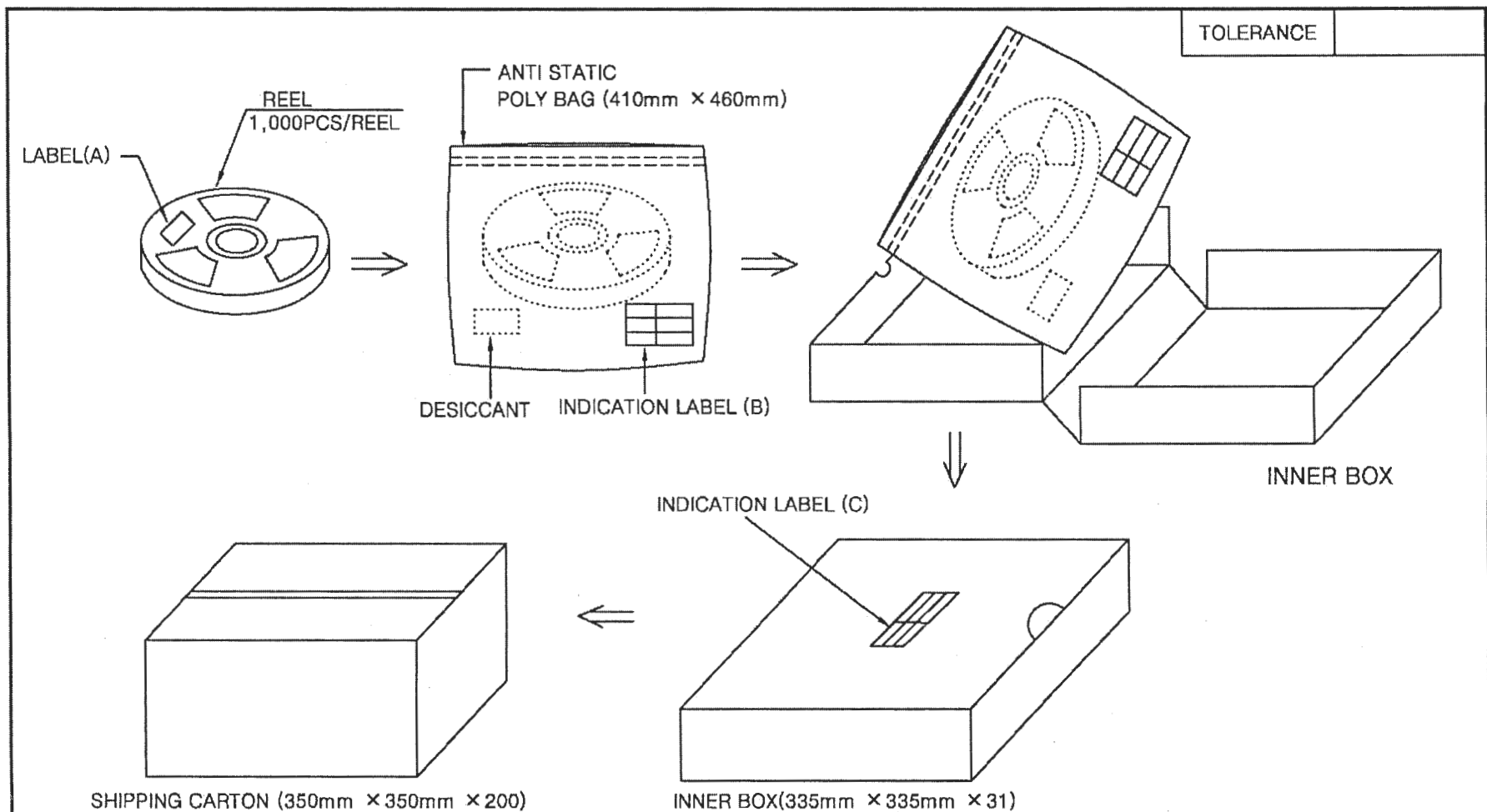

				APPROVED		MATERIAL		DATE	1999. 4. 20.
				CHECKED		FINISH		DRAWING NO	
				DESIGNED		MODEL NAME	BST0804SM-03-4T SERIES C / BOX PACKING		
NO	DATE	CHANGE NO	CHANGE CONTENTS		SCALE	UNIT : mm	International Components Corporation		



# Lead Free Assessment Form

Component Information				Lead Free composition	Peak reflow temp (reflow or wave)	MSL @ peak reflow temp
Part Numbers	Description	Lead free Compliant (Y/N)	If "No" Share plan by when ?		(Degrees C)	Moisture Sensitivity Level
BST0804SM-03-4T	TRANSDUCER	YES			260	3

### Reference Chart

Lead Free Reflow profile

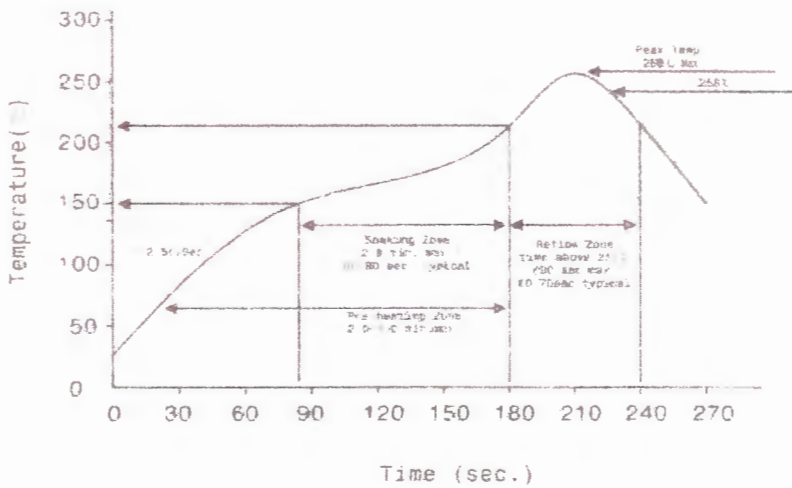

### J-STD-20B Standard (For Reference-MSL)

LEVEL	FLOOR LIFE		SOAK REQUIREMENTS			
	TIME	CONDITIONS	STANDARD		ACCELERATED EQUIVALENT *	
			TIME (hours)	CONDITIONS	TIME (hours)	CONDITIONS
1	Unlimited	±30°C/85% RH	168 +5/-0	85°C/85% RH		
2	1 year	±30°C/60% RH	168 +5/-0	85°C/60% RH		
2a	4 weeks	±30°C/60% RH	696 +5/-0	80°C/60% RH	120 +1/-0	60°C/60% RH
3	168 hours	±30°C/60% RH	192 +5/-0	80°C/60% RH	40 +1/-0	60°C/60% RH
4	72 hours	±30°C/60% RH	96 +2/-0	80°C/60% RH	20 +0.5/-0	60°C/60% RH
5	48 hours	±30°C/60% RH	72 +2/-0	80°C/60% RH	15 +0.5/-0	60°C/60% RH
6	24 hours	±30°C/60% RH	48 +2/-0	80°C/60% RH	10 +0.5/-0	60°C/60% RH
7	Time on Label (TOL)	±30°C/60% RH	TOL	80°C/60% RH		

**Note 1:** CALIBRATION - The accelerated equivalent soak requirements shall be used for verification of package reliability including electrical after time a reflow is established with the standard soak requirements. If the actual acceleration energy for diffusion is 0.4 - 0.8 xv, accelerated time times this diffusion coefficient.

**Note 2:** The standard soak time includes a default value of 24 hours for semiconductor manufacturers' procedure time (48 hours for reliability and field life) including the maximum time allowed out of the bag of the component.

**Note 3:** If the actual MSL is less than 24 hours the soak time for the component for soak conditions of 80°C/60% RH, the soak time is reduced by 1 hour for each hour the MSL is less than 24 hours. For soak conditions of 80°C/60% RH, the soak time is reduced by 1 hour for each 1 hour the MSL is less than 24 hours.

**Note 4:** If the actual MSL is greater than 24 hours the soak time must be increased 1 hour for each hour the MSL is greater than 24 hours. For each hour the actual MSL exceeds 24 hours the soak time is increased 1 hour for each 1 hour the actual MSL exceeds 24 hours.

**Note 5:** Supplier may extend the soak times in their own risk.