

INTERVOX AUDIBLE SIGNAL DEVICES

BST0905 SERIES

FEATURES

- Compact
Small and slim size of 9.0mmW × 9.0mmL × 4.5mmH
- Low profile design
- For reflow process
- Tape and reel packing

SPECIFICATIONS

TYPE	UNIT	BST0905SM-03
Rated voltage	V _{P-P}	3.6
Operating voltage	V _{P-P}	2.5~4.5
● Rated current	mA	Max 100
Coil resistance	Ω	16 ± 3
● Sound output at 10cm	dBA	Min 85(Typ 95)
Resonant frequency	Hz	2670
Operating temperature	°C	-30 to +70
Storage temperature	°C	-40 to +85
Weight	g	Max 1.0

- Value applying rated voltage(2670Hz, 1/2 duty, square wave)

DIMENSIONS

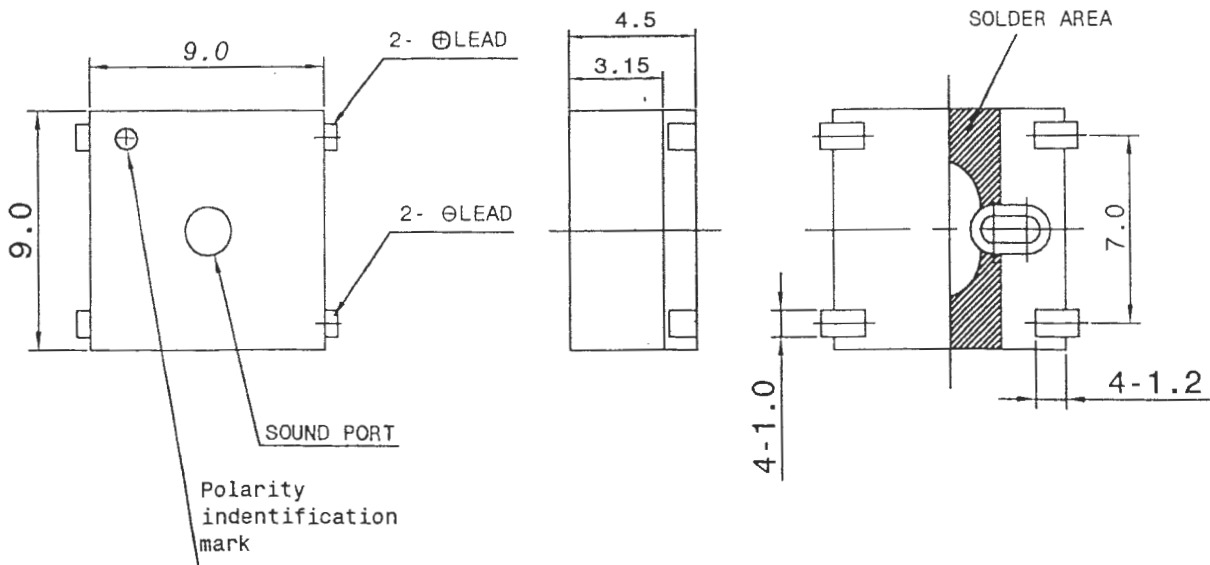

unit : mm

INTERVOX AUDIBLE SIGNAL DEVICES

BST0905SM-03
X:2.6500kHz Y:95.24dB ZA:Live Curve SSR T.RMS

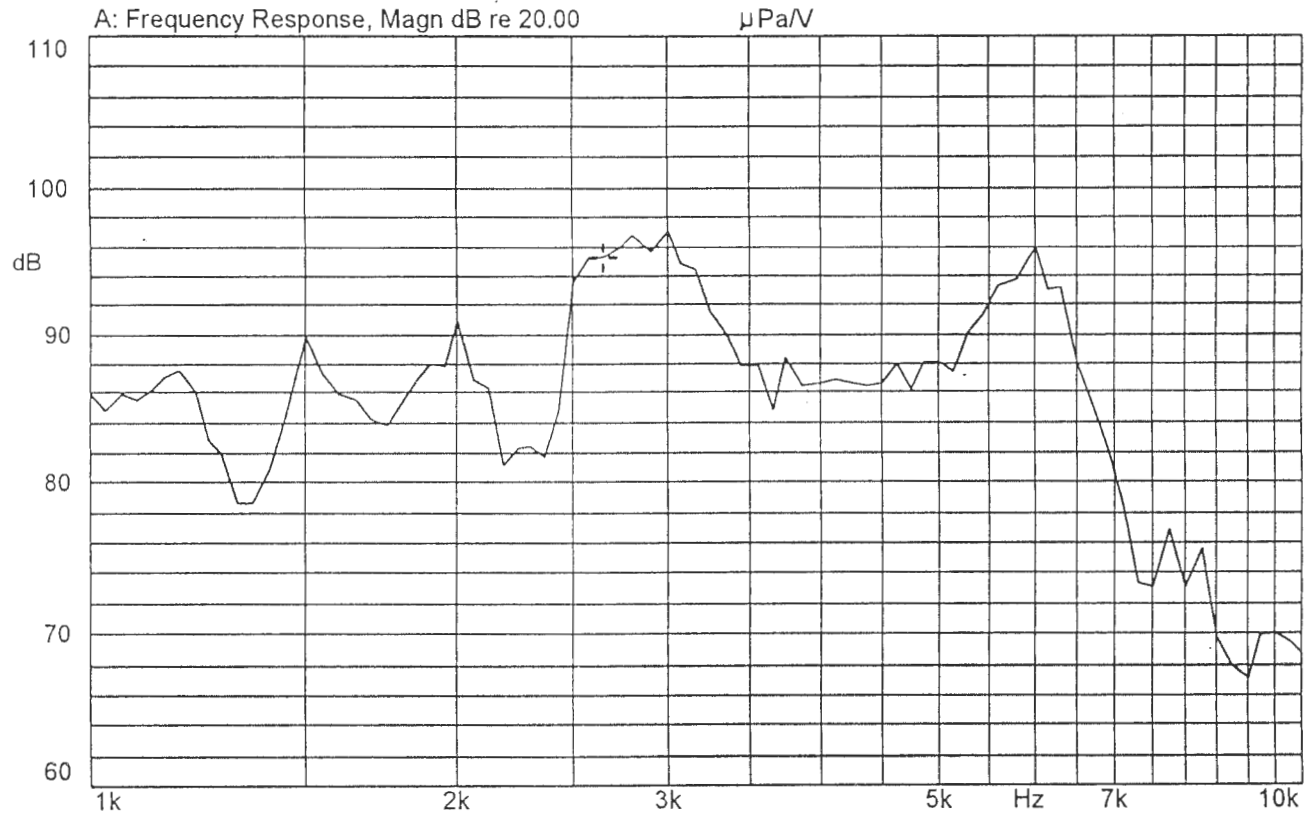

29-JUN-2000 11:14:01

Mode: SSR



INTERNATIONAL COMPONENTS CORPORATION
215 MCCORMICK DRIVE, BOHEMIA, NY 11716
FAX: 631-952-9595 FAX: 631-952-9597

DWG. NO 일반공차
TOLERANCE

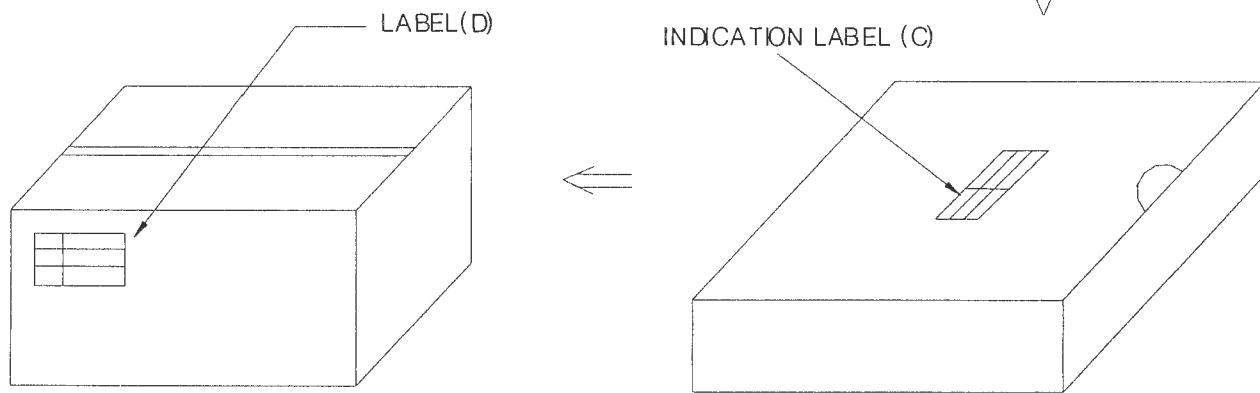
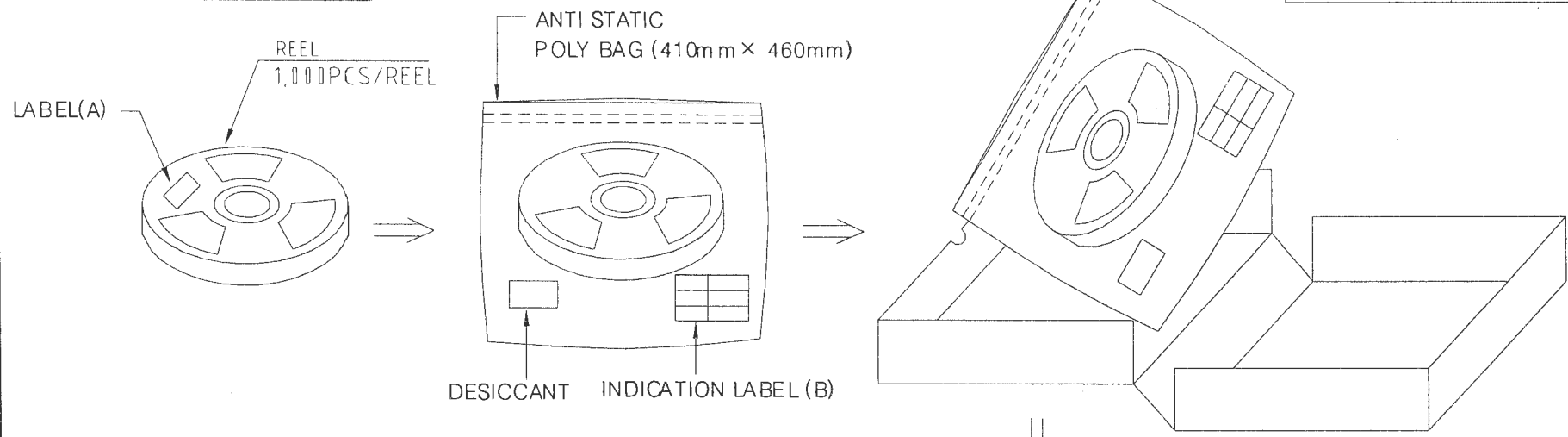

5K EA/BOX

				승인 APPROVED	재질 MATERIAL	적용기종 수량	5K EA/BOX
				검도 CHECKED	표면처리 FINISH	작성일자 DATE	1999. 4. 20.
				설계 DESIGNED	부품명 PART NAME	BST0905SM-03	
				제3각법	척도 SCALE	제품명 MODEL NAME	SMD PACKING
NO	년월일 DATE	설변통지 NO CHANGE NO	설변내용 CHANGE CONTENTS	UNIT : mm	INTERNATIONAL COMPONENTS CORP.		

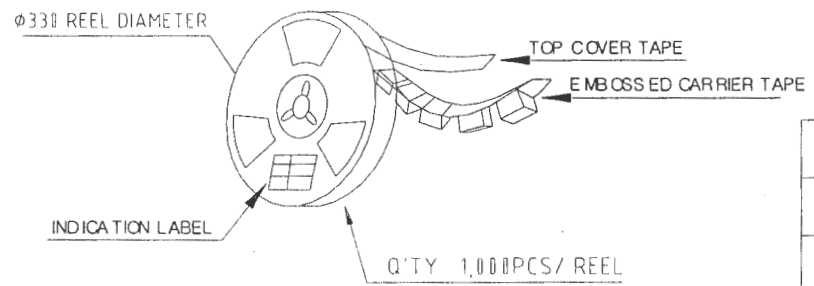
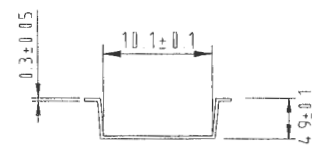
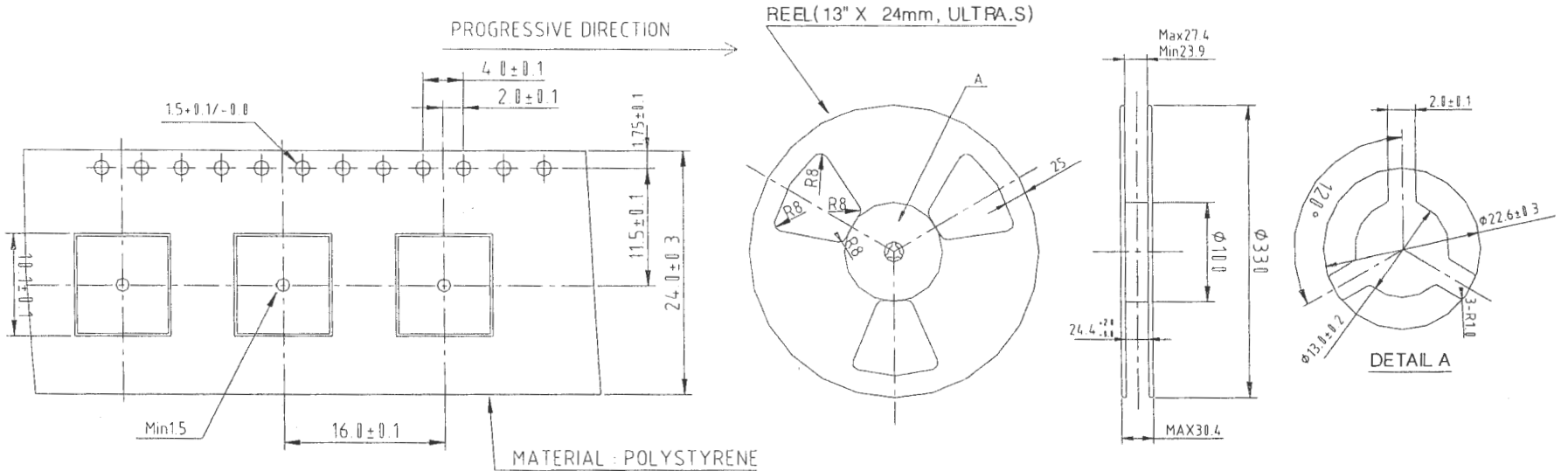

적용기종	수량

				승인 APPROVED		재질 MATERIAL		작성일자 DATE	1999. 3. 15.	
				검도 CHECKED		표면처리 FINISH		DRAWING NO		
				설계 DESIGNED		제품명 MODEL NAME		BST0905SM-03		
NO	년월일 DATE	실변동지 NO CHANGE NO	실변내용 CHANGE CONTENTS	제3각법	척도 SCALE	UNIT : mm	INTERNATIONAL COMPONENTS CORP.			