

Surface Mount Electro Acoustic Transducer BST1003SM-03 Series

Features:

- SMD Type, small and slim size magnetic buzzer.
- Reflow process available.
- Tape & Reel packaging
- Side sound port

Applications:

- Cellular phones
- Pocket pagers
- Timers
- Alarm clocks

SPECIFICATIONS:

TYPE	BST1003SM-03A	BST1003SM-03B
Rated Voltage (Vp-p)	3.6	
Operating Voltage (Vp-p)	2.0~4.5	
● Rated Current (mA)	Max 90	
Coil Resistance (Ohm)	16 ± 3	
● Sound Output at 10cm (dBA)	Min. 85 (typical 91)	
Resonant frequency (Hz)	2700	3000
Operating Temperature °C	-20 to+60	
Storage Temperature °C	-40 to +85	
Weight (Kgs)	5	

● Value applying resonant frequency (1/2 duty, square wave)

■ DIMENSIONS

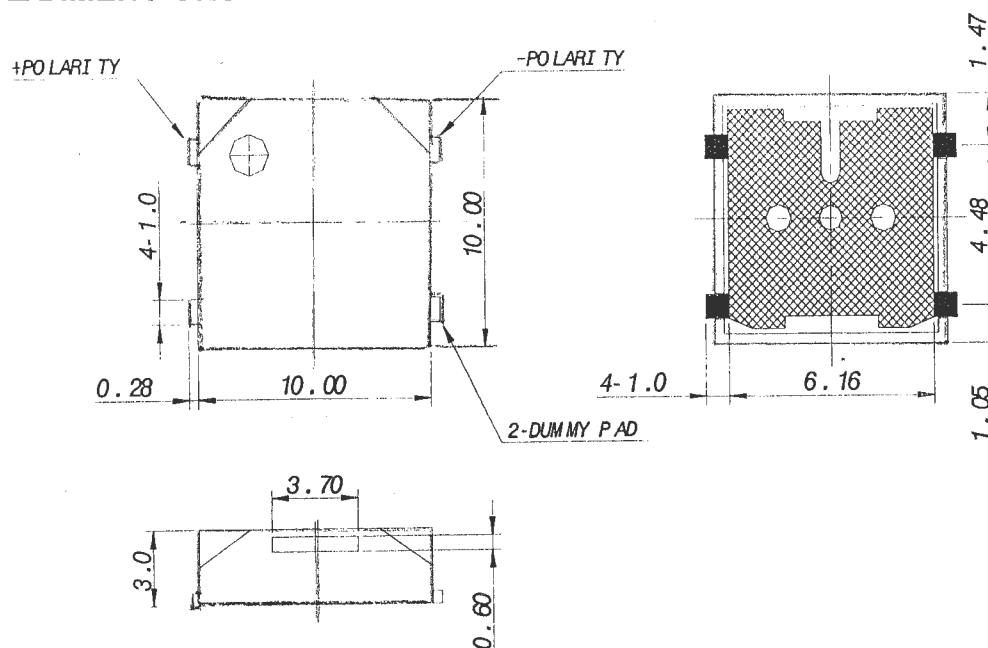

INTERVOX
International ©

INTERNATIONAL COMPONENTS CORPORATION
215 MCCORMICK DRIVE, BOHEMIA, NY 11716
FAX: 631-952-9595 FAX: 631-952-9597

Title: **Surface Mount
Electro Acoustic Transducer**

Tolerance:	Intervox Model # BST1003SM-03 Series	Rev. A
------------	--	------------------

Unit: mm	Date: 8/28/02	Sheet 1 of 1
----------	---------------	--------------

INTERVOX

Buzzers from International ©

Surface Mount Electro Acoustic Transducer BST1003SM-03-A

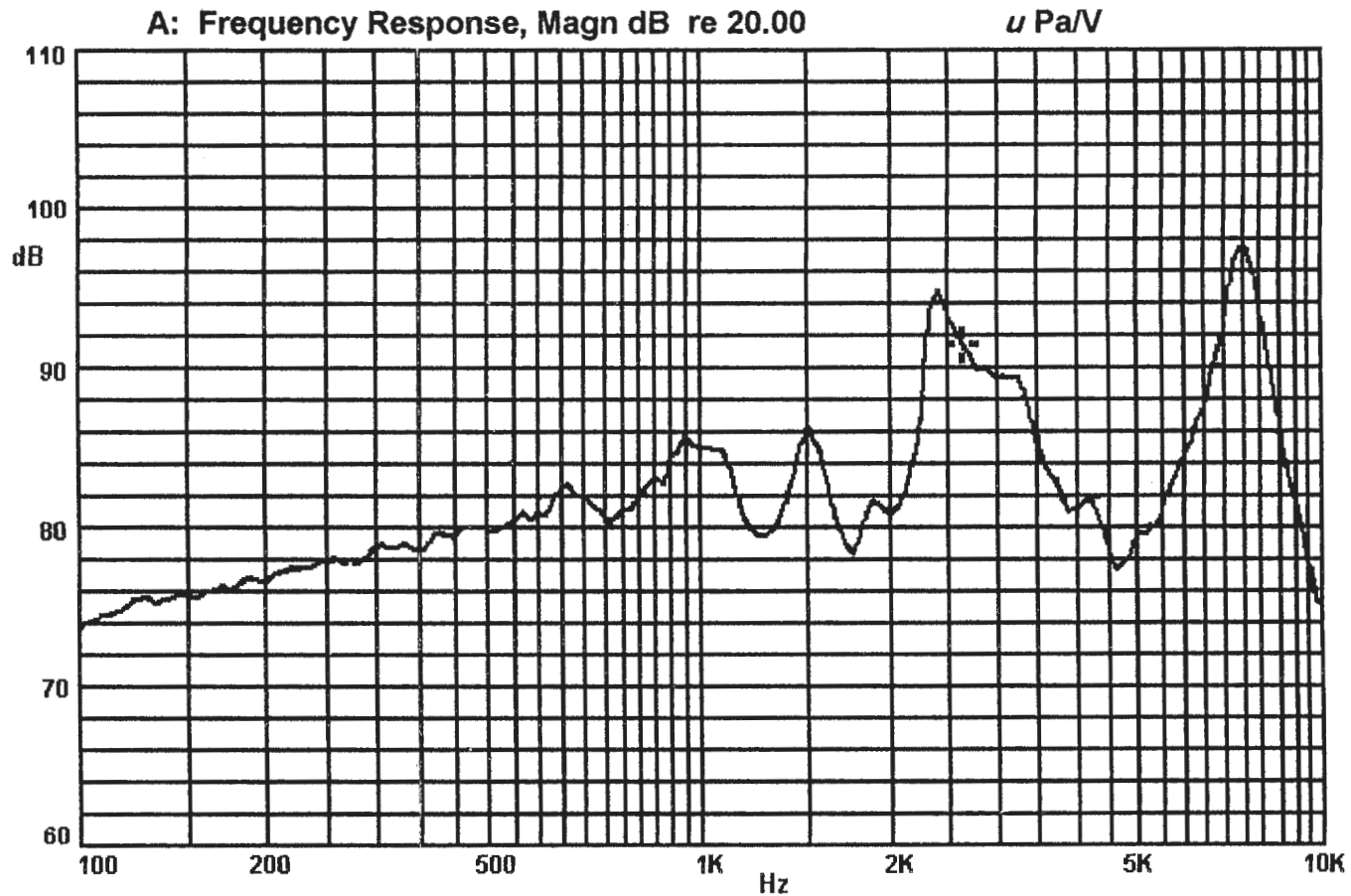

X:2.6500kHz.

*Y:91.28dB

ZA:Live Curve

SSR T. RMS

Mode: SSR

12-FEB-1999 09:43:27