

Specifications Sheet

Product Type : *Analog MEMS Surface Mount Microphone*

Product Series : *MEOM2819*

Description : *MEMS OMN ANALOG 2.75 X 1.85D 0.95H 2V < 300 Ohm 38/1 RoHS S/N 61 dB*

Electrical Specifications

Test Conditions : 23.0 ± 2.0 °C, 55.0 ± 20.0 % R.H.

Model No.		MEOM-2819BA-02-581				
Parameter	Symbol	Condition	Limits			Unit
			Min.	Typ	Max.	
Supply Voltage	V_{DD}		1.6	2.0	3.6	V
Supply Current	I_{DSS}	$V_{DD} = 2.0 V$	---	160.0	---	μA
Sensitivity	S	94.0 dB SPL @ 1KHz	-39.0	-38.0	-37.0	dB
Directivity	$D(\theta)$		Omni - Directional			
Signal to Noise Ratio	S/N	94.0 dB SPL @ 1KHz, (A-weighted)	---	61.0	---	dB
Total Harmonic Distortion	THD	94.0 dB SPL @ 1.0 KHz	---	0.2	---	%
Acoustic Overload Point	AOP	10.0 % THD @ 1.0 kHz	---	124.0	---	dB SPL
Output Impedance	Z_{out}	@ 1.0 KHz	---	---	300.0	Ω
Terminal			SMD			
Operating Temperature			-40.0 ~ +105.0			°C
Storage Temperature			-40.0 ~ +85.0 (Microphone units with package)			°C
Weight			0.02 ± 10.0 %			g

Dimensions

Unit : mm

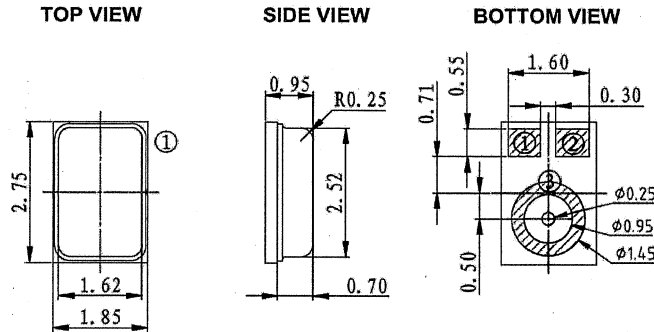

Pin Output	
Pin #	Function
1	VDD
2	Output
3	GND

Note :

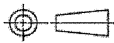

All dimensions are in millimeter (mm) otherwise specified.
Tolerance : ± 0.1 mm unless otherwise specified.

Recommended Interface Circuit

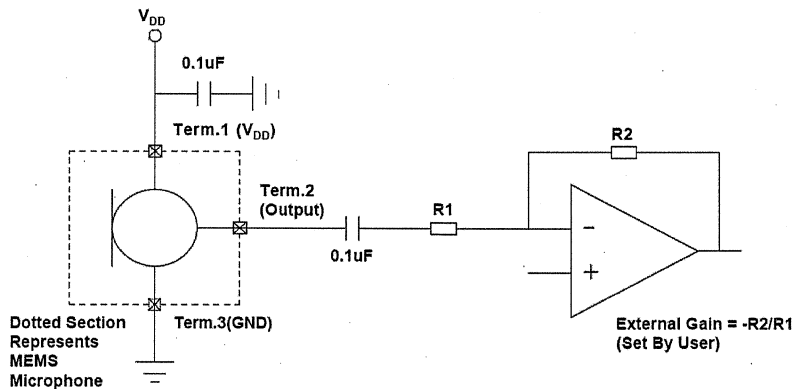

Approved By : JY
Date : 24 Apr 2019

Prepared By : LL
Date : 24 Apr 2019

Modify :	Date :	By :