

Specifications Sheet

Product Type : *Digital MEMS Surface Mount Microphone*

Product Series : *MEOM473Z*

Description : *MEMS OMN DIGITAL 4.72 X 3.76D 1.25H 2V 26/3 RoHS S/N 58 dB*

Electrical Specifications

Test Conditions: 23.0 ± 2.0 °C, 55.0 ± 20.0 % R.H., VDD = 2.0 V, fclock = 2.4 MHz

Model No.		MEOM-4737TD-00-463				
Parameter	Symbol	Condition	Limits			Unit
			Min.	Typ	Max.	
Supply Voltage	V _{DD}		1.6	---	3.6	V
Supply Current	I _{DD}	F _{CLOCK} < 1.0 K Hz	---	860.0	---	µA
Sensitivity	S	94.0 dB SPL @ 1.0 KHz	-29.0	-26.0	-23.0	dB
Directivity	D(θ)		Omni - Directional			
Signal to Noise Ratio	S / N	94.0 dB SPL @ 1.0 KHz, (A-weighted)	---	58.0	---	dB
Sleep Current	I _{SLEEP}	F _{CLOCK} < 1.0 K Hz	---	25.0	50.0	µA
Total Harmonic Distortion	THD	100.0 dB SPL @ 1.0 K Hz	---	---	1.0	%
		115.0 dB SPL @ 1.0 K Hz	---	---	10.0	%
Power Supply Rejection	PSR	100.0 mVpp square wave @ 217.0 Hz, A-weighted	---	-70.0	---	DBFS
Fall-asleep Time		(F _{CLOCK} < 1.0 K Hz)	---	---	10.0	USEC
Wake-up Time		(F _{CLOCK} ≥ 1.0 M Hz)	---	---	10.0	MSEC
Short Circuit Current	I _{SC}	Grounded Data Pin	---	1.0	10.0	mA
Output Load	C _{LOAD}	---	---	---	100.0	µF
Data Format			1 - Bit PDM			
Clock Frequency	F _{CLOCK}	---	1.0	2.4	3.2	MHz
Clock Duty Cycle	F _{DC}	---	40.0	---	60.0	%
Clock Rise Time	t _{CR}	---	---	---	10.0	NSEC
Clock Fall Time	t _{CF}	---	---	---	10.0	NSEC
Logic Input / Output Low	V _{IL}	I _{OUT} = 1.0 mA	-0.30	---	0.35 x V _{DD}	V
Logic Input / Output High	V _{I/OH}	I _{OUT} = 1.0 mA	0.65 x V _{DD}	---	V _{DD} + 0.3	V
Delay Time for Valid Data	t _{DV}	---	18.0	---	60.0	NSEC
Delay Time for Hight z	T _{DH}	---	0	---	16.0	NSEC
Terminal			SMD			
Operating Temperature			-40.0 ~ +105.0			°C
Storage Temperature			-40.0 ~ +85.0 (Microphone units with package)			°C
Weight			0.025 ± 10.0 %			g

Dimensions

Unit : mm

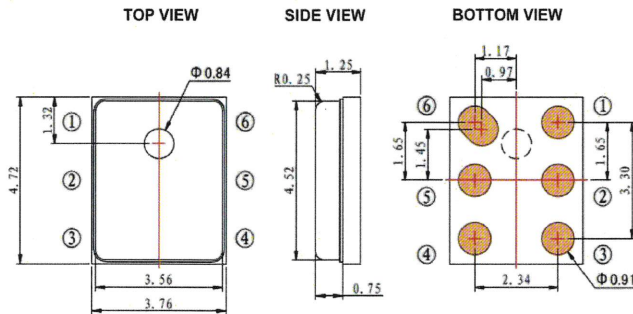

Pin Output	
Pin #	Function
1	GND
2	L/R
3	GND
4	CLOCK
5	DATA
6	VDD

Note : All dimensions are in millimeter (mm) otherwise specified.
 Tolerance : ± 0.1 mm unless otherwise specified.

Recommended Interface Circuit

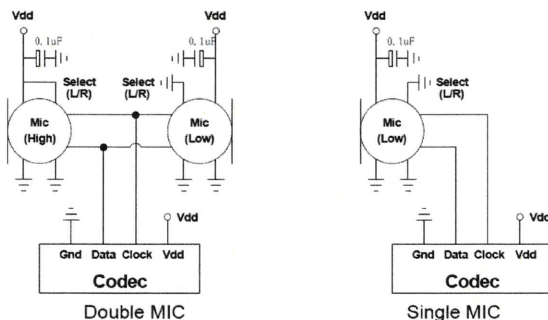

Approved By : JN Prepared By : LL
 Date : 23 Apr 2019 Date : 23 Apr 2019

Modify :	Date :	By :