

INTERVOX Speakers from International C

215 McCormick Drive, Bohemia, NY 11716 (631) 952-9595 (631) 952-9597 www.icc107.com

1.	MODEL:	S125RS-M-R5W			
2.	Dimension	Outer Diameter	32 mm.	Baffle Opening	28.3 mm.
		Height	Refer to Drawing .	Weight	7.0 Grams.
3.	Magnet	Materials	Rare Earth	Size ϕ 12.5X 1.5	mm.
4.	Nominal Impedance	8 Ω	\pm 15 %	At	1200 Hz.
5.	Power Rating	Normal	500 mW.	Maximum	1000 mW.
6.	Lowest Resonant Frequency	600	\pm 20 %		Hz.
7.	Output Sound Pressure Level (S.P.L.)	87 \pm 3 db / 0.5 Watt · 0.5 Meter.			
		Average at	800, 1000, 1200, 1500		Hz.
8.	Frequency Range	350	~ 5000 Hz.	verage SPL -	10 db.
9.	Distortion	5 %	Maximum At	1000 Hz.	500 mW.
10.	Abnormal Sound Test	Must Be Normal Test By		2.0 Volts.	Sine Wave.
11.	Load Test	White Noise With Weighted Filter		2.0 Volts.(RMS)	24 Hrs.
12.	Polarity	Diaphragm shall move Forward when Apply a Positive DC.			
		Current to the "+" or "Marked" Terminal.			

MOUNTING NOTICE

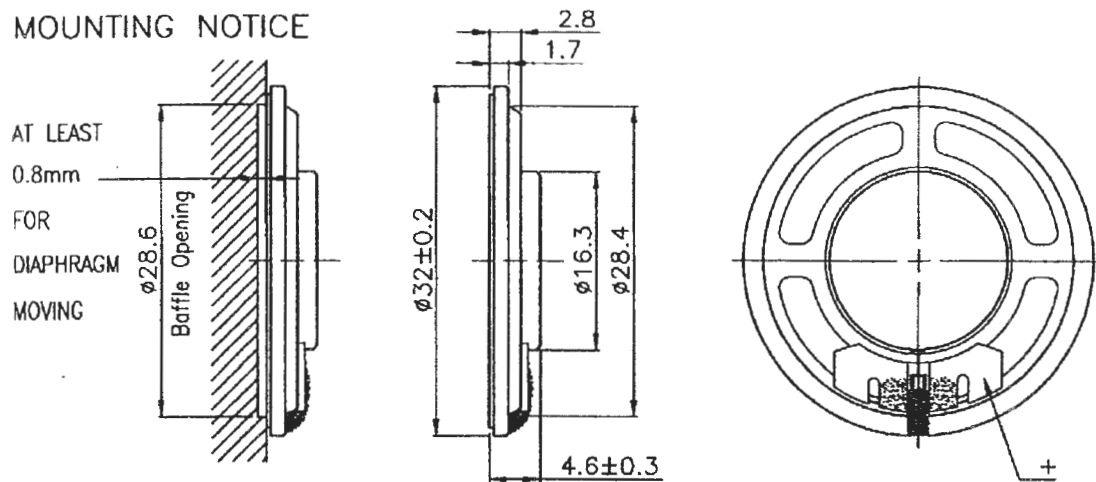

450

Unit : mm

Housing Material : METAL

INTERVOX Speakers from International ©

S125RS-M-R5W

450

VOL:2V(0.5W) DIS:0.5M

X:1.0000kHz

*Y:89.21dB

ZA:Live Curve

SSR Fund.

A: Frequency Response, Magn dB re 20.00µPa

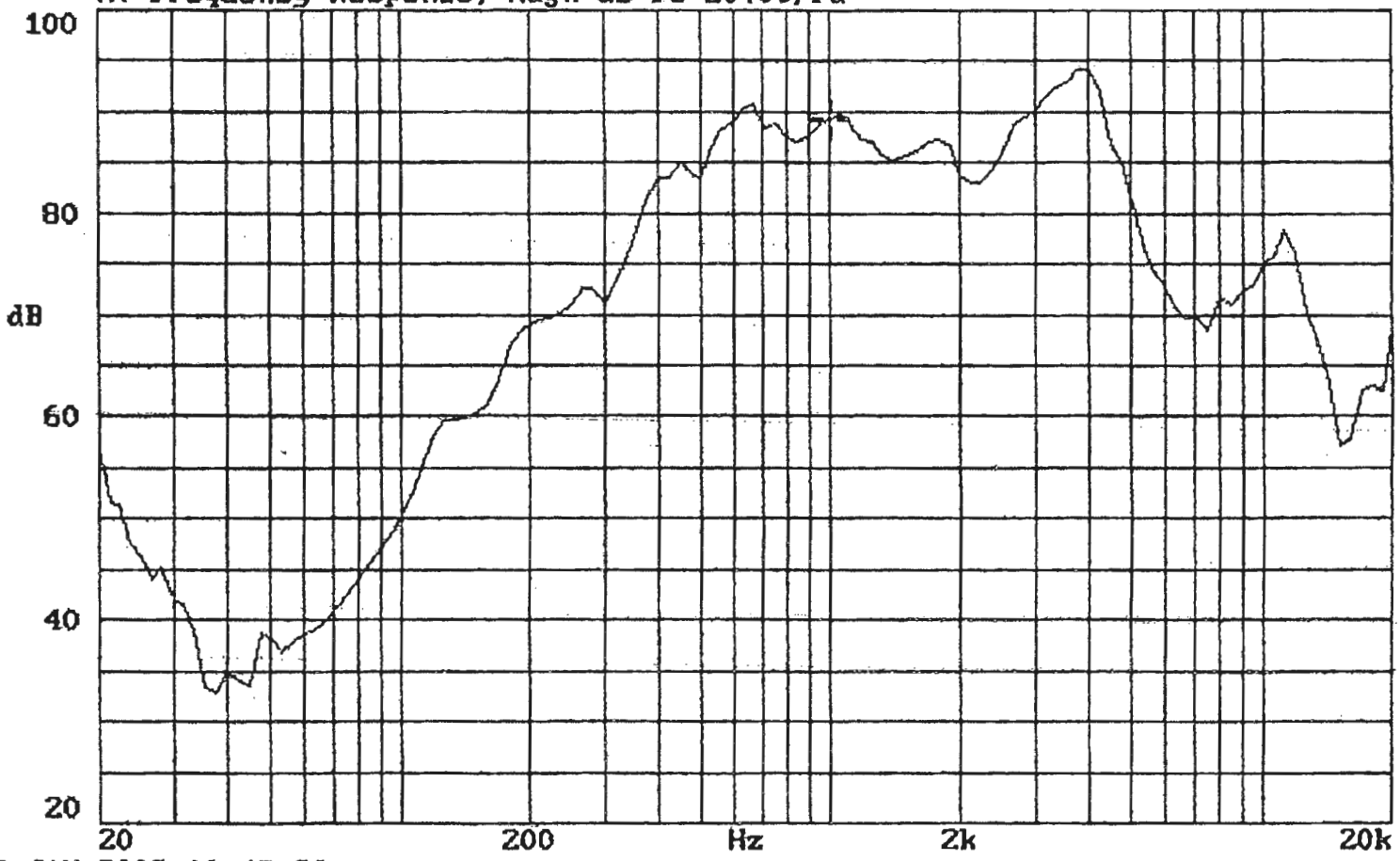

18-JAN-2002 10:48:20

Mode: SSR

