

INTERVOX Speakers from International ©

215 McCormick Drive, Bohemia, NY 11716 (631)952-9595 Fax: (631) 952-9597 e-mail: oemsales@icc107.com

1.	MODEL:	S200RL-M-R3W					
2.	Dimension	Outer Diameter	50	mm.	Baffle Opening	48.87	mm.
		Height	Refer to Drawing		Weight	13.1	Grams.
3.	Magnet	Materials	Rare Earth		Size	ø 12.5x1.5 mm.	
4.	Nominal Impedance	8 Ω	± 15 %	At	1000 Hz.		
5.	Power Rating	Normal	300	mW.	Maximum	600 mW.	
6.	Lowest Resonant Frequency	400	± 20	%	Hz.		
7.	Output Sound Pressure Level (S.P.L.)	85	± 3	db /	0.3 Watt · 0.5 Meter.		
		Average at	600,	800,	1000,	1200	Hz.
8.	Frequency Range	200	~	5000	Hz.	Average SPL - 10 db.	
9.	Distortion	5 %	Maximum	At	1k	Hz.	300 mW.
10.	Abnormal Sound Test	Must be Normal Tested By		1.6	Volts.	Sine Wave.	
11.	Load Test	White Noise with Weighted Filter		1.6	Volts.(RMS)	24 Hrs.	
12.	Polarity	Diaphragm shall move Forward when Apply a Positive DC.					
		Current to the "+" or "Marked" Terminal.					

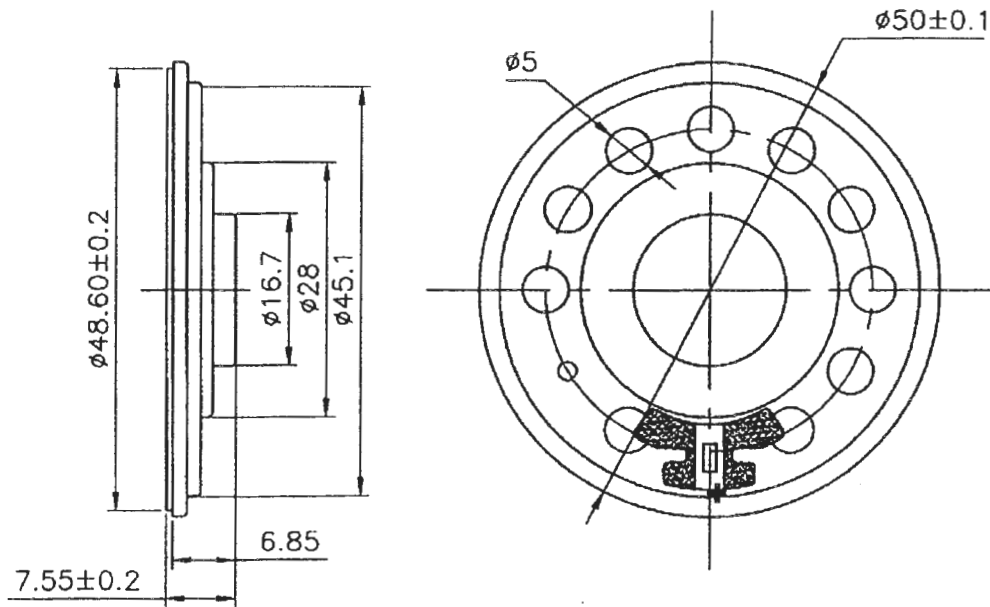

450

Unit : mm

Housing Material : METAL

INTERVOX Speakers from International ©

S200RL-M-R3W

450

VOL:1.549V(0.3W) DIS:0.5M

X:1.0000kHz

*Y:83.45dB

ZA:Live Curve

SSR Fund.

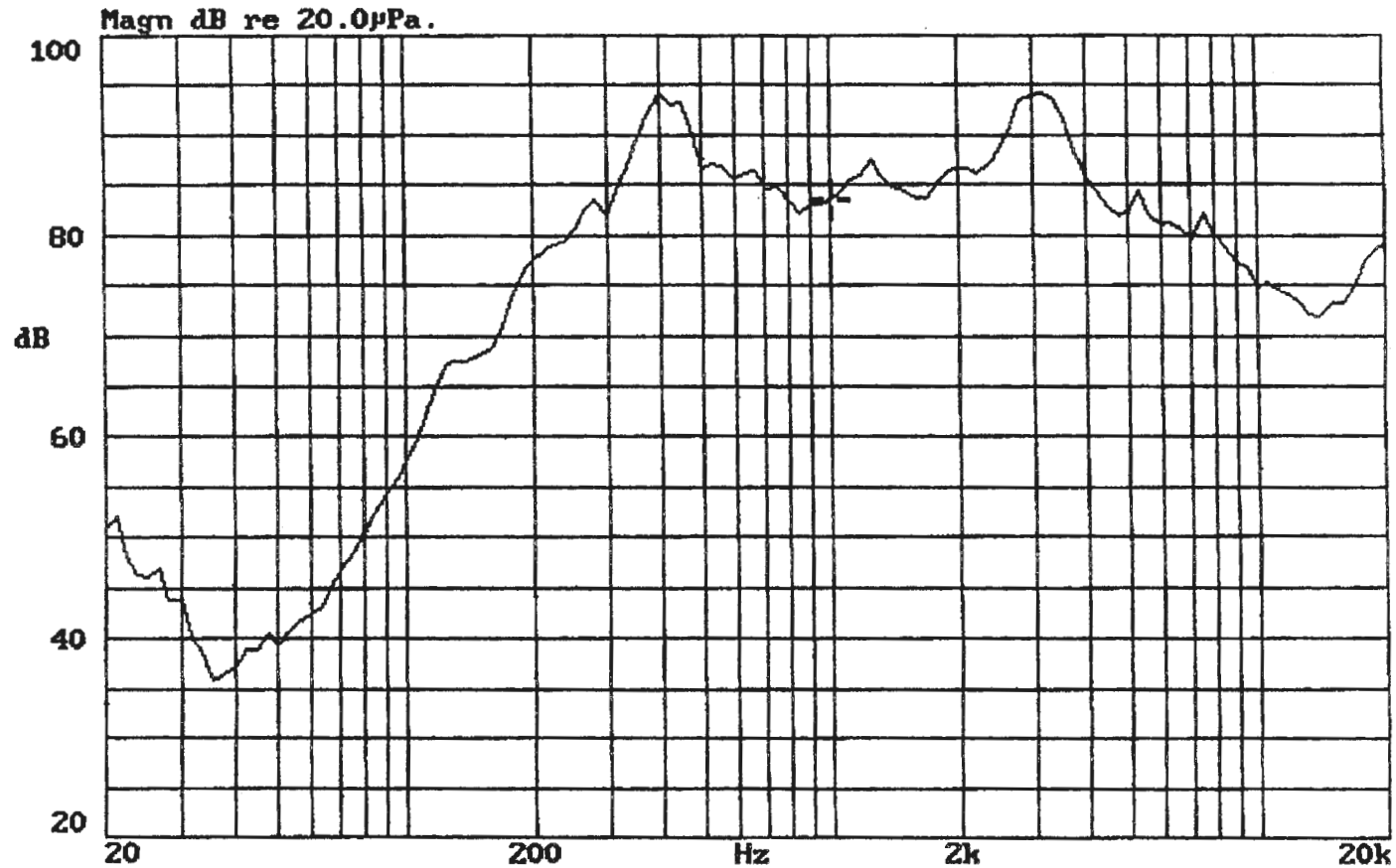

03-OCT-2000 09:29:59

Mode: SPEAKER

