

INTERVOX Speakers from **International C**

215 McCormick Drive, Bohemia, NY 11716 (631) 952-9595 (631) 952-9597 www.icc107.com

ICC Part No.	S275RA	
1. Voice Coil Imp.	8 Ω \pm 15%	At 1000 Hz 1 Volt
2. Operation	Must be normal	Program Source W
3. Buzz & Rattles	Must be normal	Sin Wave W
4. Resonant Freq.	280Hz	Without Baffle
5. Output S.P.L.	86 \pm 3 dB/W Mean Value at 0.8, 1.0, 1.2, 1.5 KHz	From 50 cm Measurement 0.5W
6. Freq. Response	FO ~ 5000 Hz \pm 10 dB	
7. Rated Freq. Response	Hz	
8. Rated Power Input	0.4W	
9. Max. Power Input	0.6W	
10. Load Test	After Test Meet Items 2 & 3	White Noise W Hours
11. Heat Test	After Test Meet Items 2 & 3	40° \pm 2° C 50% R.H. 48 Hours
12. Humidity Test		40° \pm 2° C 50% R.H. 48 Hours
13. Distortion	5% Max.	Rated Power Input 1000 Hz
14. Total Flux	Maxwell	
15. Flux Density	7000 Gauss	
16. Magnet	Material: Rare Earth	Size: 13 x 10mm Weight: .35 oz.
17. Total Weight	45.7gr.	1.61 oz.
18. Baffle Opening	64mm	
19. Outside Diameter	70mm	(Eliminate Rim: 64.5mm)
20. Total Height	21.8mm	
21. Outside Dia. Yoke Seat	32.5mm	

INTERVOX Speakers from International ©

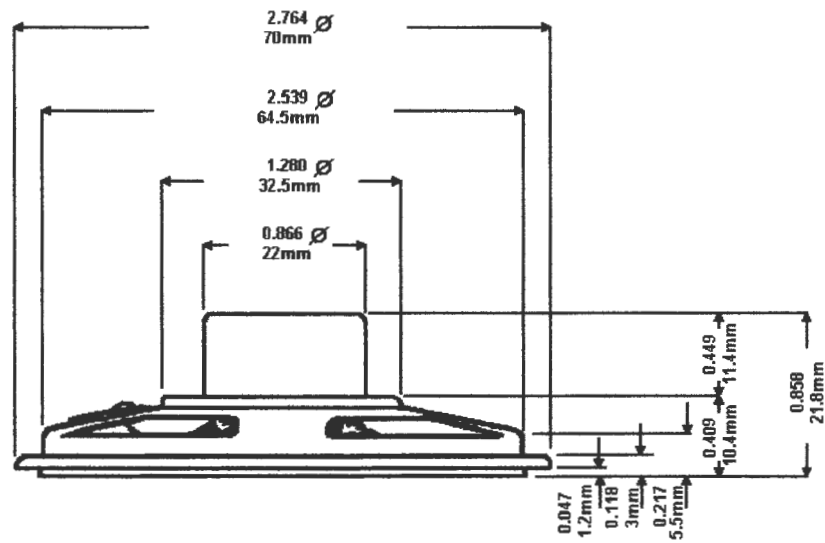
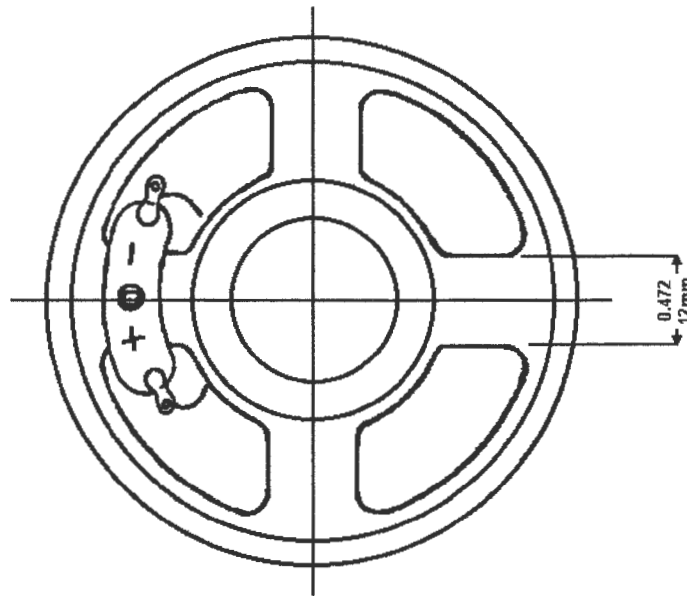

ICC PART NO.: S275RA	TOLERANCES:
SIZE: 70MM 2.75"	INCH: ± 0.004 mm: ± 0.1

INTERVOX Speakers from International ©

Measuring Object: S275RA

